

Interference management using basestation coordination in broadband wireless access networks[‡]

Mohamed H. Ahmed^{1*,†}, Halim Yanikomeroglu² and Samy Mahmoud²

¹*Faculty of Engineering and Applied Science, Memorial University of Newfoundland, St. John's A1B 3X5, Canada*

²*Department of Systems and Computer Engineering, Broadband Communication and Wireless Systems (BCWS) Centre, Carleton University, Ottawa, Canada*

Summary

This paper proposes a transmission-scheduling algorithm for interference management in broadband wireless access networks. The algorithm aims to minimize the cochannel interference using basestation coordination while still maintaining the other quality of service (QoS) requirements such as packet delay, throughput and packet loss. The interference reduction is achieved by avoiding (or minimizing) concurrent transmission of potential dominant interferers. Dynamic slot allocation based on traffic information in other cells/sectors is employed. In order to implement the algorithm in a distributed manner, basestations (BSs) have to exchange traffic information. Both real-time and non-real-time services are considered in this work. Results show that significant reduction in the packet error rate can be achieved without increasing the packet delay at low to medium loading values and with a higher but acceptable packet delay at high loading values. Since ARQ schemes can also be used for packet error rate reduction, we compare the performance of the proposed scheme with that of ARQ. Results indicate that although ARQ is more effective in reducing packet error rate, the proposed algorithm incurs much less packet delay particularly at medium to high loading. Copyright © 2006 John Wiley & Sons, Ltd.

KEY WORDS: interference management; transmission scheduling; broadband wireless access; multimedia wireless multimedia service; ARQ

1. Introduction

Broadband wireless access networks are considered as the most promising candidate for multimedia services provisioning for residential and small business areas. Multimedia services including real-time traffic (voice

and video) and non-real-time traffic (http and ftp data) are to be supported.

Since most of the multimedia traffic is inherently bursty, packet-level performance has to be investigated to ensure that the stringent quality of service (QoS) requirement of most multimedia applications

*Correspondence to: Mohamed H. Ahmed, Faculty of Engineering and Applied Science, Memorial University of Newfoundland, St. John's A1B 3X5, Canada.

†E-mail: mhahmed@engr.mun.ca

[‡]This paper was presented in part at *the 5th International Symposium on Wireless Personal Multimedia Communications (WPMC'02)*, Hawaii, U.S.A., October 2002, and at the Newfoundland Electrical and Computer Engineering Conference (NECEC'03), St. John's, Canada, November 2003.

can be met. There are many factors and parameters that affect the QoS in multimedia applications, but the most important one is the transmission scheduling since it has a direct impact on the delay, throughput and signal quality performance.

Numerous algorithms have been proposed for multimedia scheduling over wireless links. Most of these algorithms are in essence modified versions of some scheduling algorithms employed in wireline networks used to cope with the lower transmission rate and high error rate encountered in wireless environment (see e.g. [1–3]). Then, several algorithms have proposed the concept of user diversity by making use of the channel variations and allocate a lot of resources for users with good channel conditions and lower (or even no resources at all) to users with bad channel conditions [4–6]. These scheduling techniques have been studied either in isolated cells or in multiple cells but without considering the scheduling technique in the interference management. The use of packet scheduling for interference management has been proposed in References [7–9]. In Reference [7], a new technique has been proposed for time sharing between sectors using time reuse to avoid sources of major interference. An enhanced version has been proposed in Reference [8] by providing different degrees of concurrent transmission in different time slots. In Reference [9], interference management is achieved using basestation (BS) coordination assuming that a local cluster of BS has a pre-determined time schedule of on–off periods. This assumption is hard to implement in reality. However, the main drawback in References [7–9] is the static nature of the time allocation technique, which can waste some of the system resources particularly with bursty traffic sources of multimedia services. Another approach for interference reduction is proposed in Reference [10]. This approach uses the channel sense concept to avoid dominant interferers.

In this paper, we propose a dynamic time slot allocation algorithm, inter-sector intra-sector scheduling (ISISS), that minimizes the cochannel interference. By taking the cochannel interference into account in multiple cells, the scheduling problem becomes more challenging since the transmission scheduling has to consider not only the packet delay and throughput performance but also the signal quality in terms of the signal to interference ratio. BSs exchange information about the available traffic. Then, each BS schedules its local traffic based on this information. Concurrent transmission by potential dominant interfering users

is avoided (or at least minimized) by assigning different time slots to those users.

Automatic repeat request (ARQ) schemes can also be used to decrease the packet error rate (PER). Hence, it is essential to compare the performance of both schemes (ISISS and ARQ) for multimedia transmission. We compare the packet-level performance of the proposed algorithm and that of ARQ in terms of PER and packet delay.

The rest of the paper is organized as follows. Section 2 presents the systems model. The proposed algorithm is described in Section 3. The Performance of the proposed algorithm is analyzed in Section 4. The comparison between the proposed algorithm and ARQ is presented in Section 5. Finally Section 6 contains the summary and conclusions.

2. System Model

A hexagonal cellular structure with a wraparound structure is used in the simulation. Each cell is divided into six sectors. Sinc-shaped beam pattern with 60° beamwidth is used at both BSs and subscriber stations (SSs). While the BS antenna beams are fixed, it is assumed that the antenna beams at the SSs are electronically steered to point at the direction of serving BSs. This is feasible since fixed SSs is assumed in this work.

The channel model consists of an exponential path loss model with an exponent (n) of 3, lognormal shadowing with a standard deviation (σ) of 8 and flat Rayleigh fading. Shadowing samples are spatially correlated with a correlation coefficient of 0.5 for 1 m displacement. Temporally correlated Rayleigh fading samples are generated using rounded (bell-shaped) Doppler spectrum with a 3-dB frequency of 2 Hz [11]. The Rayleigh fading samples from different BSs to each user are mutually independent.

A frequency reuse plan of 1/6 is employed such that the total spectrum is divided into six equal sub-bands allocated to the six sectors and reused in each cell. The employment of directional antennas at both BSs and SSs enables such a tight frequency reuse plan.

Time is divided into frames with a frame-duration of 5 ms consisting of nine slots in a TDMA fashion. This work focuses on the downlink (DL) performance since it is the limiting factor in many multimedia services. However, the proposed algorithm can be implemented in the uplink (UL) as well.

Two services are considered in this study, namely video service as an example of real-time services and

Table I. Traffic model parameters of the internet service.

IPP no.	Packet arrival rate (packet/s)	On to off transition rate ($R_{on_off} s^{-1}$)	Off to on transition rate ($R_{off_on} s^{-1}$)
IPP ₁	22.79	0.194	0.1455

Table II. Traffic model parameters of the video service.

IPP no.	Packet arrival rate (packet/s)	α_1	α_2
IPP ₁	112.38	1.14	1.22
IPP ₂	154.75	1.54	1.28

internet (HTTP/TCP and FTP) traffic as an example of non-real-time services. Packets are generated using n -interrupted Poisson processes (IPP). The traffic model used in this work is proposed for broadband wireless access networks in Reference [12]. For the internet traffic, one IPP is used to model the traffic with on and off sojourn times following exponential distribution with transition rates R_{on_off} and R_{off_on} , respectively. For the video service, two IPPs are used with on and off sojourn times following Pareto distribution with parameters α_1 and α_2 respectively. The parameters of the traffic model are listed in Tables I and II. The packet size in both cases is equal to 192 bytes [12].

The superposition of IPP models the self-similar traffic of different multimedia services. The targeted bit error rates (BER) are 10^{-4} and 10^{-6} for the video service and data service respectively. The maximum packet delay (D_{max}) for video service is 200 ms. No maximum delay is specified for the data service.

16-QAM with bit-interleaved coded modulation (BICM) [13] is used in this work. The required SIR values corresponding to the targeted BER levels mentioned above are 10.93 and 9.25 dB for the data service and video service, respectively.

Fixed users are assumed in this work since the analysis is intended to analyze the performance of the proposed algorithm in broadband wireless access networks. However, the proposed algorithm can also be employed in wireless mobile networks. It is assumed that users are uniformly distributed and are assigned to the best serving BS (not necessarily the nearest one). It is assumed that the system is interference-limited. Hence, noise is neglected and only cochannel interference is considered.

3. Inter-Sector Scheduling with Basestation Coordination

The proposed approach schedules the packet transmission in each sector taking into account the traffic information in the sectors of potential dominant interferers. The traffic information is exchanged every time-frame using the fixed network connecting the BSs or by wireless broadcasting. The potential dominant interferers for users in sector 1 in cell 4 (to be referred to as sector 1/cell 4), for instance, are the signals for users in sector 1/cell 1 and sector 1/cell 7[§] as shown in Figure 1. Therefore, BS 4 sends the traffic information of users in sector 1/cell 4 to BSs 1 and 7. Meanwhile, BS 4 receives the traffic information of users in sector 1/cells 1 and 7. This information includes the arrival time and service type of each packet waiting in the transmission queue. BSs 1, 4 and 7 use this information to avoid (or minimize) concurrent transmission in these three sectors (sector 1/cells 4, 1 and 7). We call this set of sectors that includes mutual potential dominant interfering BSs an interference group. By eliminating the concurrent transmission within each interference group, the interference level can be drastically reduced. Obviously, there are other users that can cause interference to users in sector 1/cell 4 including users in sector 1/cells 2, 3, 5, 6 and 9. However, their interference level is much less than that of sector 1/cell 1 and 7 because of the directional antennas used at both BSs and SSs. Mathematically, the time slot allocation vector in sector i /cell j (S_{ij}) can be written as

$$S_{ij} = [b_{ij}(0), b_{ij}(1), b_{ij}(2), \dots, b_{ij}(8)]$$

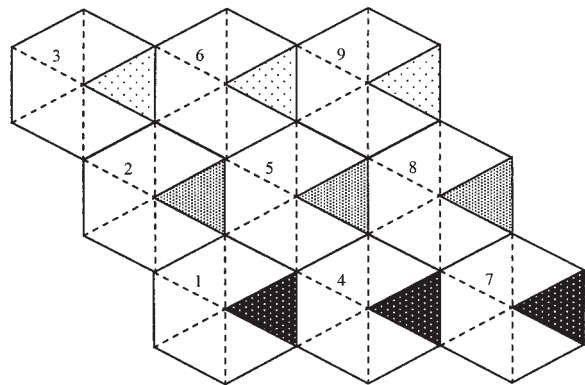

Fig. 1. Interference groups of sector 1.

[§]Users in sector 1/cell 7 cause interference in the downlink because of the assumed wraparound grid.

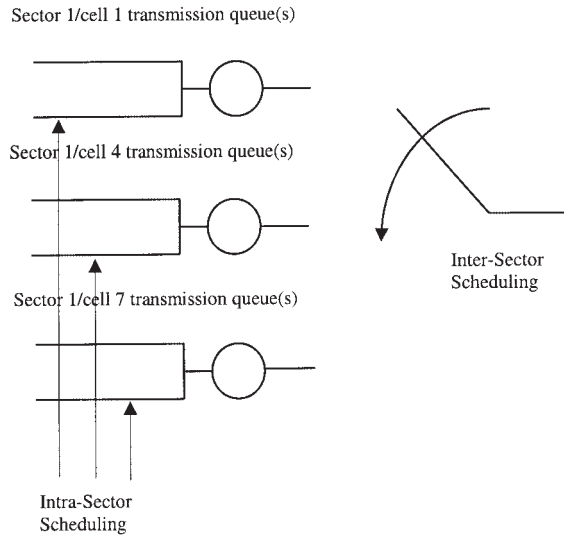

Fig. 2. Intra-sector and inter-sector scheduling.

where $b_{ij}(k)$ is the k th-slot indicator that takes the values 1 for a busy slot and 0 for an idle slot. For instance, the slot allocation vector in sector 1/cell 4 is $S_{14} = [b_{14}(0), b_{14}(1), b_{14}(2), \dots, b_{14}(8)]$.

Since sector 1/cells 1, 4 and 7 constitute an interference group, the algorithm ensures that the time slot allocation vectors (S_{11} , S_{14} , S_{17}) are orthogonal.

The number of occupied slots in each sector and the decision, of which time slots are allocated to which users in each sector, depends on the employed intra-sector and inter-sector scheduling discipline. The intra-sector scheme schedules the packet transmission of all users inside a sector while the inter-sector scheme schedules the traffic transmission of different sectors within the interference group as shown in Figure 2. First come first serve (FCFS), weighted round-robin (WRR), weighted fair queuing (WFQ) or any other discipline can be used at any of the two levels. For instance, with FCFS as the intra-sector and inter-sector scheduling disciplines, the BS of each sector schedules its packet transmission based on their arrival time and the arrival time of packets in other sectors within the interference group. With WRR as the inter-sector scheduling discipline, each sector in the interference group is given portions of the time resources in a round-robin fashion with different weights to each class of service. The proposed technique is transparent in the sense that it can be integrated with any intra-sector and inter-sector scheduling schemes. Different scheduling schemes can be used at the two levels. For example FCFS can be used

as the intra-sector scheduling scheme while WRR is used at the inter-sector scheduling scheme.

The proposed technique can be employed in any cellular wireless networks regardless of the number of sectors per cell and the frequency reuse plan. However, the size and pattern of interference groups might vary depending on the network configuration.

It is apparent that the proposed technique reduces the number of available resources (time-slots) per sector, which can lead to a higher packet delay and a lower throughput particularly at higher loading values. However, the throughput reduction is compensated by the enhancement of the signal quality so that the packet error rate is reduced and as a result the net throughput can be as high as the case without BS coordination or even higher.

For non-real-time data services such as e-mail, ftp or http traffic, this increase in the packet delay can be tolerated as long as it is bounded and it leads to a better signal quality (lower packet error rate). For real-time services such as video and voice traffic, the condition of slot-allocation vector orthogonality can cause high packet loss in the packet queuing delay. If it is found that the packet delay exceeds a certain threshold (D_{th}), a congestion flag is set and the algorithm relaxes the condition of slot allocation vector orthogonality within the interference group of the congested users. Hence, the algorithm allows users in congestion to use all available time slots even if the potential dominant interferers are using the same slots. If the packet delay goes below D_{th} , the algorithm returns to its original mode demanding the orthogonality of time slot allocation vectors within each interference group.

4. Performance of the Proposed Algorithm

The performance metrics used to analyze the proposed algorithm are:

- *PER*: A packet is considered in error if the SIR value is less than the targeted SIR level.
- *Packet delay* (D_p) and *packet delay jitter* (D_j): Mean value is measured for both metrics.
- *Packet loss* (*PL*): A packet is considered as a lost packet if the packet delay exceeds the maximum delay of the real-time service (D_{max}).
- *Throughput*: Total and net throughput (in packet per frame per sector) are measured. Erroneous transmitted packets are excluded in the net throughput calculation.

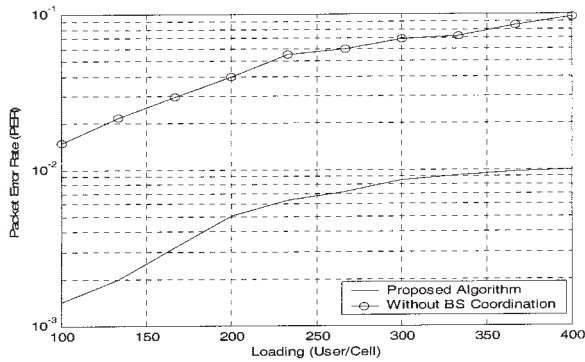

Fig. 3. Packet error rate (PER) of the internet traffic.

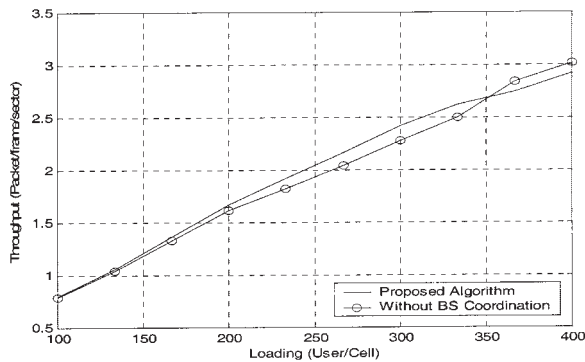

Fig. 4. Net throughput of the internet traffic.

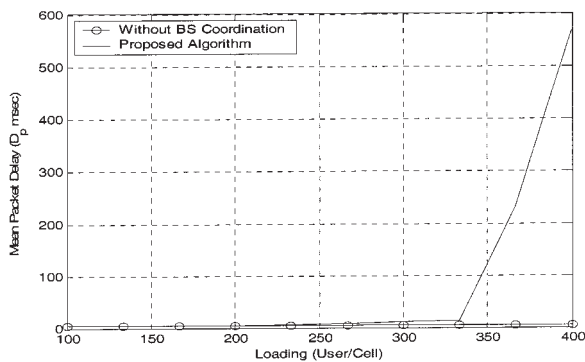

Fig. 5. Mean packet delay of the internet traffic.

Computer simulation has been used for analyzing the system performance with BS coordination using the proposed algorithm and without BS coordination (intra-sector scheduling only).

Figures 3–5 depict the dependence of the performance metrics on the loading defined as the number of users per cell for non-real-time service (internet traffic).

Figure 3 shows that the proposed algorithm reduces the PER by almost one order of magnitude. For

instance, at loading value of 150 user/cell, PER drops from 2.38×10^{-2} without BS coordination to 2.2×10^{-3} with the proposed algorithm. If the maximum tolerable PER is chosen to be equal to 2×10^{-2} , the maximum loading value will be limited to 130 user/cell without BS coordination. With BS coordination using the proposed algorithm, PER does not exceed 1×10^{-2} even with more than 400 user/cell.

Figure 4 shows the net throughput for both cases. The total throughput of the proposed algorithm is slightly less than that of no BS coordination. The total throughput is not plotted due to space limitation. Although the proposed algorithm slightly reduces the total throughput, the net throughput values of both cases are always very close since the gain from reducing PER due to the proposed algorithm compensates (and sometimes overweighs) the reduction in the total throughput.

The penalty of this performance enhancement is the increasing packet delay but only at high loading values as depicted in Figure 5. At low to medium loading, the packet delay increase due to the proposed algorithm is insignificant. At high loading values (>330 user/cell), the packet delay of the proposed algorithm starts to increase exponentially. However, the packet delay is still in the acceptable range taking into account the delay tolerance of the non-real-time traffic. If the maximum packet delay is specified such that the mean delay should be less than 200 msec, the maximum number of users will be limited to 370 user/cell when the proposed algorithm is employed. This shows that the network capacity (or maximum loading) is delay-limited when the proposed algorithm is used while the network capacity is interference-limited if there is no BS coordination. The proposed algorithm slightly increases the packet delay jitter (D_j). The mean delay jitter is found to be constant and equal to 1.5 msec with no BS coordination but it ranges from 1.5 to 4.4 msec with the proposed algorithm.

Figures 6–8 show the dependence of the performance metrics on the loading for real-time service (video traffic). The proposed algorithm is analyzed at the following four values for the delay threshold (D_{th}): 25, 50, 75 and 100 msec.

As shown in Figure 6, at low to medium loading values, PER is reduced by almost one order of magnitude; however at high loading values, PER is only reduced by almost 50%. This is because at high loading values, the algorithm does not always keep the slot allocation vector orthogonality. It is evident that the value of D_{th} has no impact on PER values.

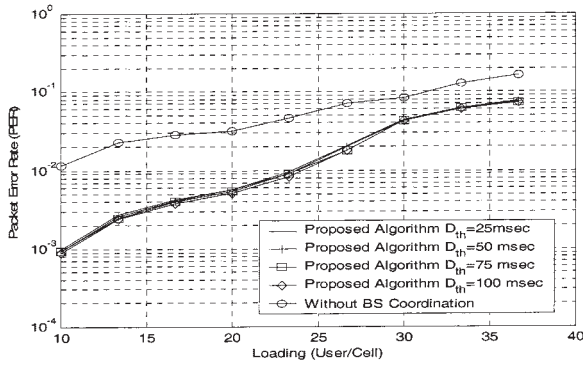

Fig. 6. PER of the video traffic.

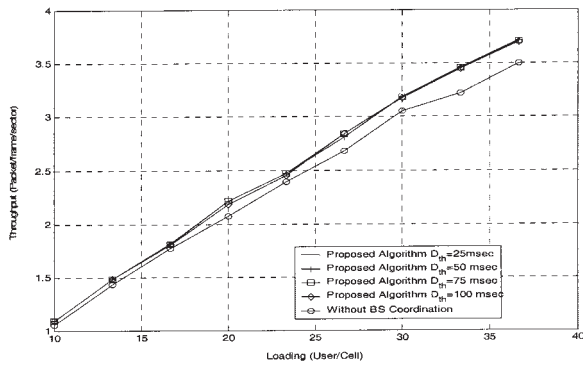

Fig. 7. Net throughput of the video traffic.

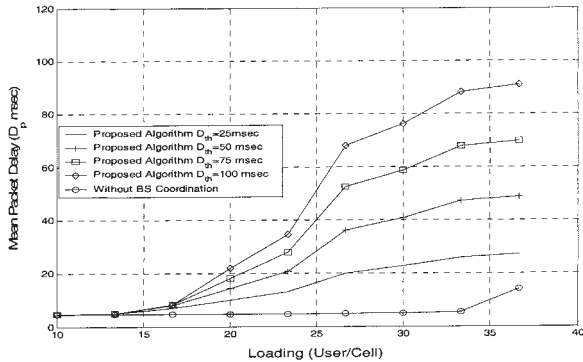

Fig. 8. Mean packet delay of the video traffic.

Figure 7 shows that the proposed algorithm slightly increases the net throughput. As in the case of non-real-time traffic, the total throughput is slightly reduced due to the proposed algorithm. However, the net throughput is enhanced due to the significant reduction in PER.

From Figure 8, it is apparent that the packet delay shows high dependence on the value of D_{max} particularly at high loading. For instance, at loading value of

30 user/cell, the mean packet delay (D_p) is 22.9, 40.7, 58.5, 76.3 msec for the four values of D_{th} mentioned above. It is evident that the proposed algorithm can limit the packet delay at (or slightly higher than) D_{max} . All performance metrics, except the packet delay, does not show any dependence on D_{th} . Therefore, it is better to choose a smaller value for D_{th} to have a smaller packet delay. As in the non-real-time traffic case, the proposed algorithm slightly increases the packet delay jitter (D_j). The mean delay jitter is found to be constant and equal to 1.2 msec with no BS coordination but it ranges from 1.5 to 1.8 msec with the proposed algorithm. The PL is found to be equal to zero for all cases even at high loading values.

5. Performance Comparison with ARQ

In order to analyze the performance of ARQ, the system is modeled as M/G/1 system as shown in Figure 9. Assuming that all errors are detectable, PER of ARQ scheme (PER_{ARQ}) can be given by

$$PER_{ARQ} = PER_0^{m+1} \tag{1}$$

where PER_0 is the PER without ARQ and m is the maximum number of retransmission. The assumption of having all errors detectable is reasonable taking into account that in fixed wireless access networks, CRC-32 is employed for error detection [14]. Limiting the number of retransmission is necessary since for real-time applications it is more efficient to drop the delayed packet rather than trying to retransmit it after exceeding a certain delay threshold value. The mean packet delay (D_p) is given by

$$D_p = 0.5T_f + \frac{\lambda E[\tau^2]}{2(1-\rho)} \tag{2}$$

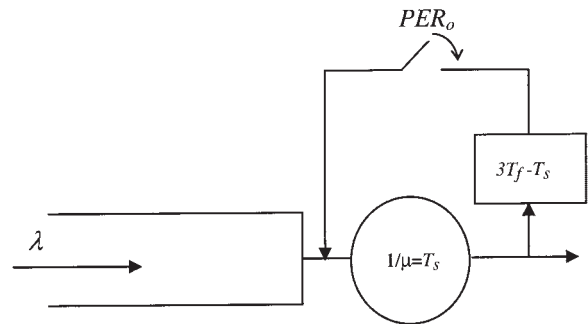

Fig. 9. ARQ M/G/1 model.

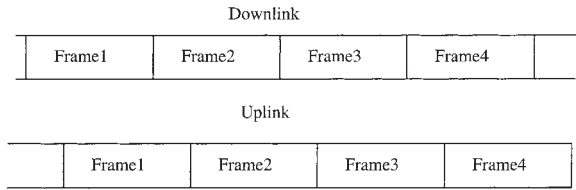

Fig. 10. Downlink/uplink frames.

where T_f is the frame duration, λ is the packet arrival rate, ρ is the utilization factor which is equal to λ/μ , where $1/\mu$ is the packet transmission time without any retransmission (i.e. without ARQ) which is equal to slot duration (T_s) and $E[\tau^2]$ is the second moment of the packet transmission time with ARQ (τ). The first term of D_p ($0.5T_f$) is the framing delay, while the second term is the queuing delay of M/G/1 systems [15].

In order to calculate $E[\tau^2]$, the probability mass function (pmf) of τ has to be determined. As shown in Figure 10, if a packet in frame 1 in DL is erroneously detected, then a negative acknowledgement (NACK) will be sent in frame 2 in UL. As a result, the same packet will be scheduled for transmission in frame 4 in DL since packets to be transmitted in frame 3 had to arrive before the frame starting point. Hence, each retransmission incurs an additional delay of $3T_f$. Then, the pmf of τ can be expressed as

$$Pr(\tau = T_s + 3iT_f) = (1 - PER_0)PER_0^i \quad (3)$$

where i is the number of retransmission ($i = 0, 1, \dots, m$).

Figure 11 shows PER of the proposed algorithm and ARQ (with $m = 1$ and 2). It is apparent that ARQ is more effective in reducing PER particularly at low to medium loading and with higher maximum number

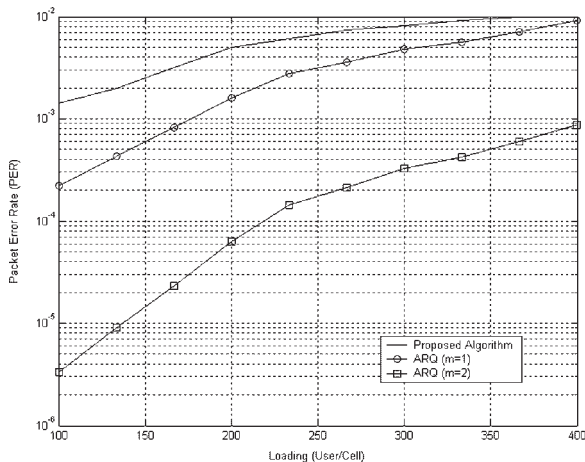

Fig. 11. PER of the proposed algorithm and ARQ.

of retransmission (m). For instance, at 100 user/cell, PER is reduced from 1.49×10^{-2} with the proposed algorithm to 2.1×10^{-4} with ARQ ($m = 1$) and to 3.3×10^{-5} with ARQ ($m = 2$), while at 400 user/cell ARQ reduces PER from 1×10^{-2} to 9×10^{-3} ($m = 1$) and to 8.7×10^{-4} ($m = 2$). This enhancement in PER comes at the expense of higher packet delay (D_p) as depicted in Figure 12. At low loading values the proposed algorithm and ARQ have the same value of D_p , which is equal to the framing delay.

At medium loading values, ARQ has a higher D_p but still tolerable. For instance, at loading values of 300 user/cell, D_p is increased from 7.7 msec with the proposed algorithm to 42.3 msec with ARQ ($m = 1$) and to 88.6 msec with ARQ ($m = 2$).

At high loading values, D_p of ARQ is much higher than that of the proposed algorithm. For example, at 350 user/cell, D_p is increased from 110 msec with the proposed algorithm to 400 msec with ARQ ($m = 1$) and to more than 600 msec with ARQ ($m = 2$).

6. Summary and Conclusion

A novel technique for interference management has been proposed. The proposed algorithm minimizes the concurrent transmission of potential dominant interferers using the orthogonality of the slot allocation vectors. The proposed algorithm can achieve lower PER and slightly better throughput at the expense of larger but acceptable packet delay. However, the increase in the packet delay can be tolerated in non-real-time services as long as it is bounded. With real-time services, the algorithm relaxes the condition of slot allocation vectors if the packet delay exceeds a certain threshold (D_{th}). The performance of various intra-sector and inter-sector scheduling schemes with mixed traffic sources and with different classes of services are currently being investigated.

A comparison of the packet-level performance of the proposed algorithm and ARQ is presented in this paper. It is shown that PER reduction due to ARQ is higher than that of the proposed algorithm. However, ARQ causes much higher packet delay especially at medium to high loading values. Hence, at low loading values ARQ has a better performance in terms of PER and D_p , while at medium to high loading values it is shown that the proposed algorithm outperforms ARQ.

Although the analysis in this paper is performed in broadband fixed wireless access networks, the proposed technique is generic and flexible enough to be adopted in various wireless and mobile networks.

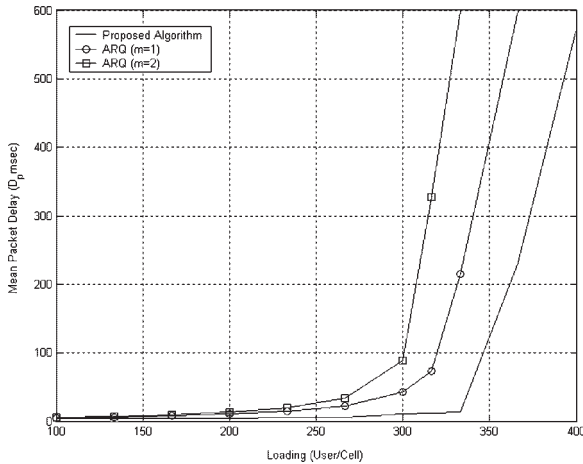

Fig. 12. Mean packet delay (D_p) of the proposed algorithm and ARQ.

Developing a joint scheme that uses ARQ at low loading values and BS coordination (as in the proposed algorithm) at higher loading values is considered for future research.

Acknowledgment

The authors thank Prof. David Falconer for his helpful comments throughout this work.

References

- Solana A, Palacio F. Scheduling and quality of service in W-CDMA. In *Proceedings of ACT'99*, June 1999; pp. 795–800.
- Lee K, El Zarki M. Scheduling real-time traffic in IP-based cellular networks. In *Proceedings of PIMRC'2000*, September 2000; pp. 1202–1206.
- Dillinger M, Luo J, Schulz E. Radio resource scheduling algorithms for mixed VoIP and HTTP traffic in HIPERLAN/2 system. In *Proceedings of IST'2001*; pp. 469–474.
- Viswanath P, Tse D, Laroia R. Opportunistic beamforming using dumb antennas. *IEEE Transactions on Information Theory* 2002; **48**(6): 1277–1294.
- Liu X, Chong E, Shroff N. Transmission scheduling for efficient wireless utilization. In *Proceedings of IEEE Infocom '2001*, April 2001; pp. 776–786.
- Inoue M, Wu G, Hase Y. Link-adaptive resource scheduling for a wireless message transport. In *Proceedings of IEEE Globecom'98*, November 1998; pp. 2223–2228.
- Fong T, Henry P, Leung K, Qiu X, Shankaranarayanan N. Radio resource allocation in fixed broadband wireless networks. *IEEE Transactions on Communications* 1998; **46**(6): 806–817.
- Leung K, Srivastava A. Dynamic allocation of downlink and uplink resource for broadband service in fixed wireless networks. *IEEE Journal of Selected Areas in Communications* 1999; **17**(5): 990–1006.
- Mailaender L, Huang H, Viswanathan H. Simple inter-cell coordination schemes for a high speed CDMA packet down-

link. In *Proceedings of IEEE VTC'00 Spring*, Tokyo, Japan, May 2002.

- Omiyi P, Haas H. Maximizing spectral efficiency in 4th generation OFDM/TDMA TDD hybrid cellular mobile/ad-hoc wireless Communications. In *Proceedings of IEEE VTC-Spring 2004*.
- Erceg V, Hari K, Smith M, Baum D, Sheikh K, Tappenden C, Costa J, Bushue C, Sarajedin A, Schwartz R, Barnlund D. Channel models for fixed wireless applications. *IEEE 802.16.3c-01/29r1*, February 2001.
- Baugh C, Huang J. Traffic model for 802.16 TG3 simulations. *IEEE 802.16.3c-01/30r1*, March 2001.
- Cair G, Taricco G, Biglieri E. Bit-interleaved coded modulation. *IEEE Transactions on Information Theory* 1998; **44**(3): 927–946.
- IEEE 802.16: Standard air interface for fixed broadband wireless access systems, <http://www.P802.16ab-01/01r2>.
- Leon-Garcia A. *Probability and Random Processes for Electrical Engineering*. Reading, MA: Addison-Wesley, 1994.

Authors' Biographies



Samy A. Mahmoud is dean of the Faculty of Engineering and Design, Carleton University. He was the chair of the Department of Systems and Computer Engineering, Carleton University from 1987 to 1997. His main research work is in the areas of wireless communication systems and the transmission of voice and video signals over high-speed networks. He has published over 200 papers in these fields in recent years and supervised 32 doctoral and 85 M.Eng. theses to completion. Dr Mahmoud graduated with the M.Eng. and Ph.D. in electrical engineering from Carleton University in 1971 and 1975, respectively. He co-authored a major book on “Communication Systems Analysis and Design”, published in 2004 by Pearson Prentice Hall. His recent research work in the field of radio-over-fiber has resulted in several archival publications and eight patent applications. Dr Mahmoud has been active in three provincial and federal networks of excellence (TRIO, CITO, and CITR) both as principal investigator, project leader and research thrust leader. He is one of the founding researchers of TRIO and CITO and served for 6 years as leader for the mobile and satellite research thrust. He formulated and directed in this role the main focus of the research in the mobile and satellite thrust. He recently led a major initiative to establish the National Capital Institute of Telecommunications (NCIT), a joint research organization involving several large international companies in the telecommunications and computer industries, leading university researchers, and scientists and engineers from two major Canadian Government research laboratories (CRC and NRC). The NCIT was launched with a total of \$25 million in funding from the Government of Canada, the Province of Ontario and industrial partners. Throughout his academic career, Dr Mahmoud maintained close links and joint research activities with industry, including two sabbatical years with industry and major consulting appointments, involving formulation of strategic research directions. He spent the last sabbatical leave with Nortel, where he worked in the area of efficient transmission of voice over ATM

network and his research work resulted in a major patent application and a new product line. He was a member of the founding Executive Board of CANARIE. He has also served as a senior research advisor, reviewer, and chair of research audit board in the European ACTS program in the mobile communications area. His research work received several international and national awards, including two best paper awards for publications in the *IEEE Transactions on Vehicular Technology* and two TRIO feedback awards for best technology transfer to industry. He is also a co-recipient of the 1994 national stentor award in telecommunications, given in recognition of outstanding Canadian collaborative research in telecommunications. He serves as a senior consultant to a number of national and international regulatory agencies in the field of spectrum management and frequency coordination.



Mohamed H. Ahmed received his B.Sc. and M.Sc. degrees in electronics and communications engineering from Ain Shams University, Cairo, Egypt in 1990 and 1994, respectively. He obtained his Ph.D. in electrical engineering in 2001 from Carleton University, Ottawa. From 2001 to 2003, he worked as a senior research associate at the Department of Systems and Computer Engineering, Carleton University. In April 2003, he joined the Faculty of Engineering and Applied Science, Memorial University of Newfoundland as an assistant professor of Electrical and Computer Engineering. Dr Ahmed served as a technical program committee member of various conferences and a guest editor for *Wiley Journal on Wireless Communications and Mobile Computing*. Dr Ahmed won the Ontario Graduate Scholarship for Science and Technology in 1997, the Ontario Graduate Scholarship in 1998, 1999, and 2000, and Communication and Information Tech-

nology Ontario (CITO) graduate award 2000. His research interests include wireless access techniques, resource management in wireless networks, smart antennas, 3G and 4G wireless systems, wireless Internet and multimedia services, and fixed wireless networks.



Halim Yanikomeroglu was born in Turkey in 1968. He received his B.Sc. degree in Electrical & Electronics Engineering from the Middle East Technical University, Ankara, Turkey, in 1990, and a M.A.Sc. degree in Electrical Engineering (now ECE) and his Ph.D. in Electrical and Computer Engineering from the University of Toronto, Canada, in 1992 and 1998, respectively. He was with the Research and Development Group of Marconi Kominikasyon A.S., Ankara, Turkey, from January 1993 to July 1994. Since 1998, Dr Yanikomeroglu has been with the Department of Systems & Computer Engineering at Carleton University, Ottawa, Canada, where he is now an associate professor with tenure. His research interests include almost all aspects of wireless communications. Dr Yanikomeroglu has been involved in the steering and technical program committees of numerous international conferences in communications; he has also given several tutorials in such conferences. He was the Technical Program Co-Chair of the IEEE Wireless Communications and Networking Conference 2004 (WCNC'04). He is an editor for *IEEE Transactions on Wireless Communications*, and a guest editor for *Wiley Journal on Wireless Communications and Mobile Computing*; he was an editor for *IEEE Communications Surveys and Tutorials* for 2002–2003. Currently he is serving as the vice-chair of the IEEE Technical Committee on Personal Communications. Dr Yanikomeroglu is a registered professional engineer in the province of Ontario, Canada.