

# Third Generation Wireless Systems

Professor Roshdy H.M. Hafez  
Department of Systems and Computer Engineering  
Carleton University  
Phone: 613-520-5731  
Fax: 613-520-5727  
email: [hafez@sce.carleton.ca](mailto:hafez@sce.carleton.ca)  
<http://www.sce.carleton.ca/faculty/hafez.html>

# Third Generation Wireless Systems

- Second Generation (2G) Systems
- Goals of The Third Generation Systems
- Candidate RTT Technologies
- Cdma2000 Highlights
- 3G Network Models
- Research Areas (Admission Control)

# 1G & 2G Wireless Systems

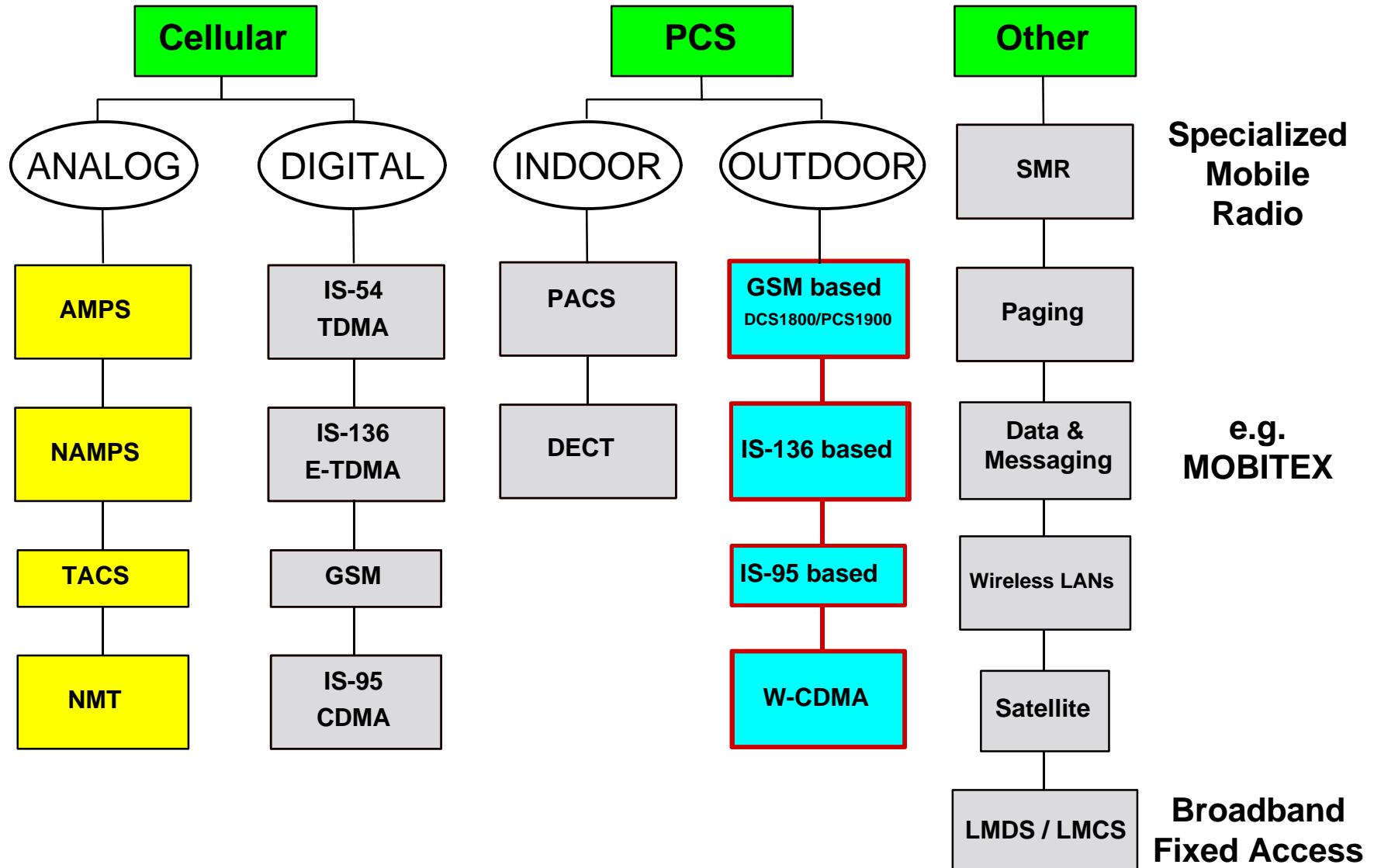

# Second Generation Wireless Systems

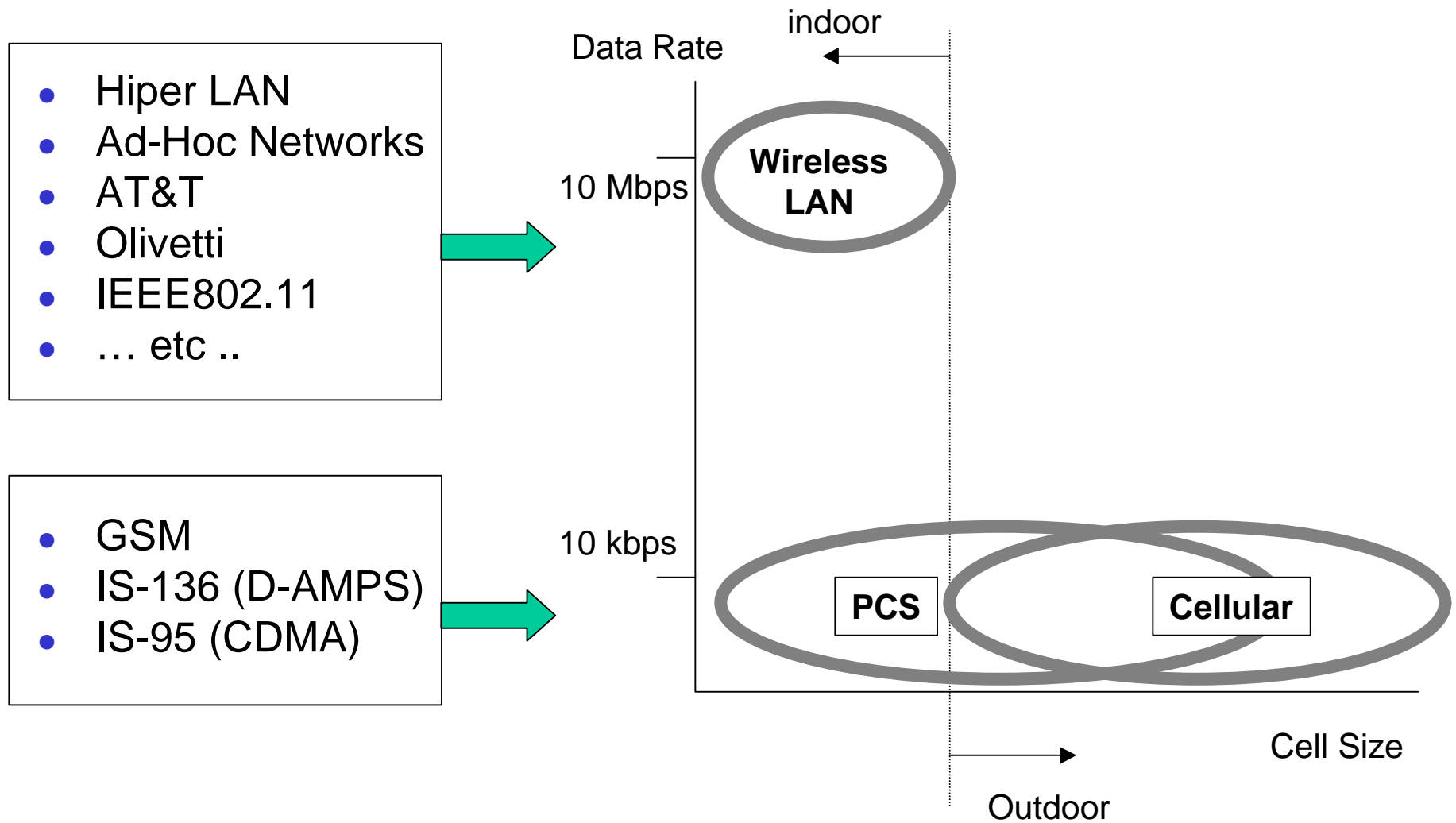

# Goals of The Third Generation

---

- Wide range of operating wireless environments
  - Indoor / Outdoor
  - High mobility (vehicular) / low mobility
- Wide range of transmission rates:
  - 1.2 kbps - 2 Mbps
- Support for different transmission modes
  - Circuit switched voice and data
  - Packet switched data
- Support for a wide range of services
- Multimedia QoS control capabilities
- Compatibility and inter-operability with 2G CDMA
- Network interface standards for inter-operability among different core networks

# Three Wireless Environments

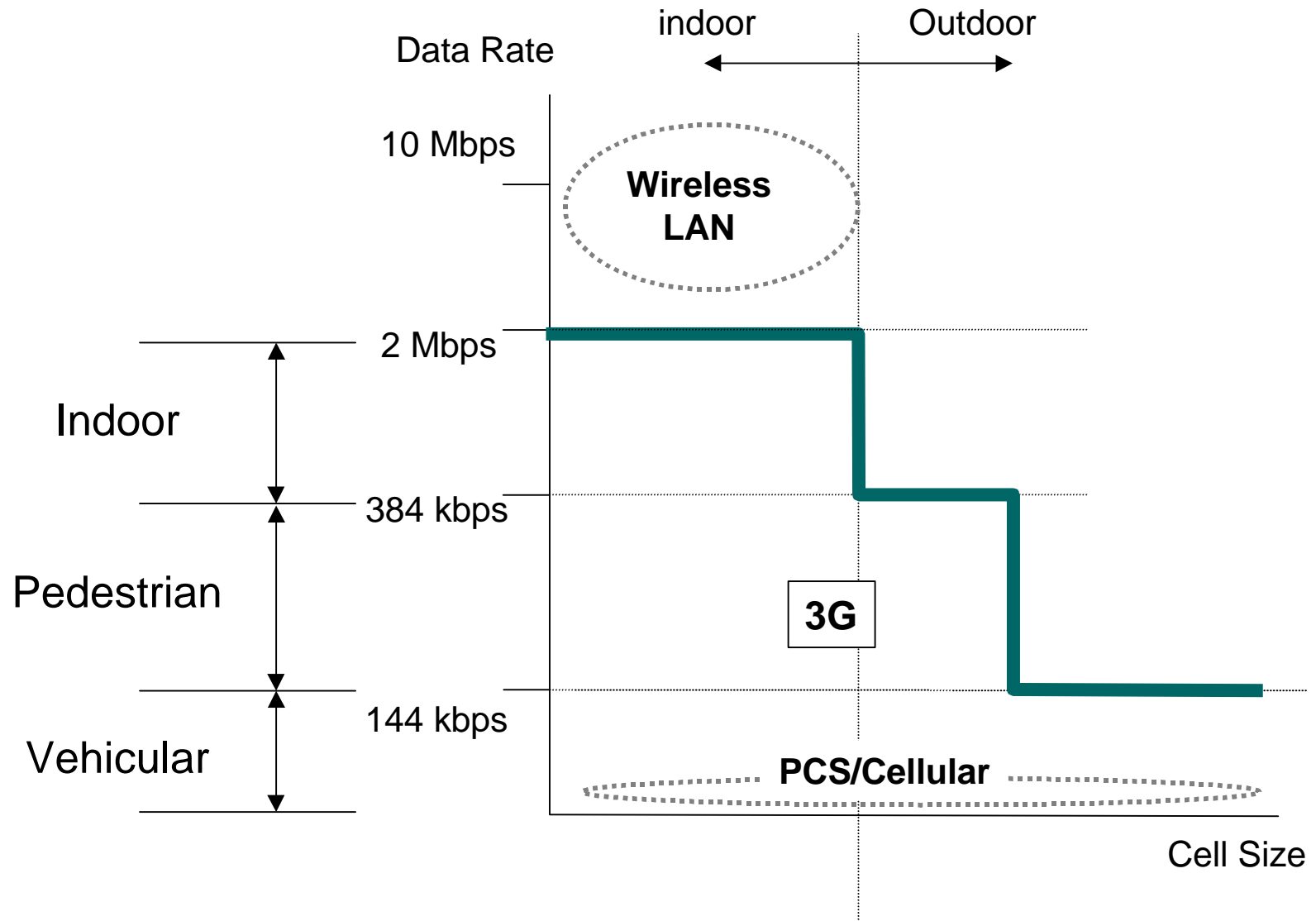

# 3G Evaluation Objectives

	<b>INDOOR</b>	<b>PEDESTRIAN</b>	<b>VEHICULAR</b>
Service	Bit rate (kbps) BER Channel Activity	Bit rate (kbps) BER Channel Activity	Bit rate (kbps) BER Channel Activity
Low Delay Bearer for Speech	8 - 16 - 32 $\leq 1.0E-03$ 50%	8 - 16 - 32 $\leq 1.0E-03$ 50%	8 - 16 - 32 $\leq 1.0E-03$ 50%
Low Delay Data Circuit-switched	64 - 144 - 384 - 512-1024-2048 $\leq 1.0E-06$ 100%	64 - 144 - 384 $\leq 1.0E-06$ 100%	64 -144 $\leq 1.0E-03$ 100%
Long Delay Constrained Circuit-switched	64 - 144 - 384 - 512-1024-2048 $\leq 1.0E-06$ 100%	64 - 144 - 384 $\leq 1.0E-06$ 100%	64 -144 $\leq 1.0E-03$ 100%
Unconstrained Delay Data Packet-switched	64 - 144 - 384 - 512-1024-2048 $\leq 1.0E-06$ (Model Specified)	64 - 144 - 384 $\leq 1.0E-06$ (Model Specified)	64 -144 $\leq 1.0E-03$ (Model Specified)

# Packet Traffic Model

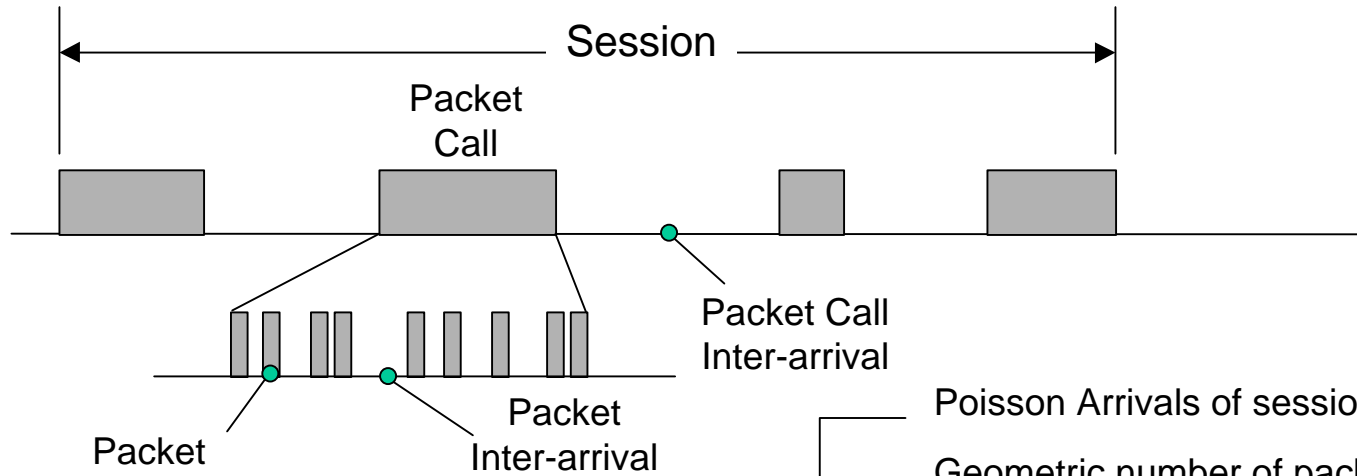

- Data User
- $P_A$ 
    - Class A
      - Poisson Arrivals of sessions
      - Geometric number of packets calls per session (114)
      - Geometric packet call inter-arrival times (1 sec)
      - One packet per packet call
      - Geometric packet size (90 bytes)
  - $P_B$ 
    - Class B
      - Poisson Arrivals of sessions
      - Geometric number of packets calls per session (5)
      - Geometric packet call inter-arrival times (120 sec)
      - Petro distributed number of packets per packet call
      - Geometric packet inter-arrival times (.01 s)
      - Fixed packet size (480 bytes)

# Radio Transmission Technologies (RTT)

---

- There are 14 proposals submitted to ITU:

- ◆ 1 (indoor only)
- ◆ 9 (indoor/outdoor)
- ◆ 4 (satellite)

- Out of the 9 indoor/outdoor proposals

- ◆ 1 TDMA
- ◆ 1 Hybrid TDMA/CDMA
- ◆ 7 CDMA

- The best known CDMA proposals are

- ◆ **Cdma2000**      North American based on IS-95
- [ ◆ **W-CDMA**      ARIB Japan
- ◆ **UTRA-W-CDMA**    ETSI Europe

# Why CDMA ?

---

- **Radio Coverage**

- Easy to add, split or reshape cells
- Require fewer cells than TDMA systems
- Cells boundaries automatically adjust to the traffic load

- **Signal Quality**

- Mitigate fading (particularly broadband CDMA)
- Soft hand-off provides seamless radio coverage
- Less interference to and from other radio systems

- **Power Control**

- Long battery life

- **Multimedia**

- CDMA is a natural multiplexing scheme for different traffic types
- Dynamic resource allocation with minimum central control

# The Basic Concept of Multimedia CDMA

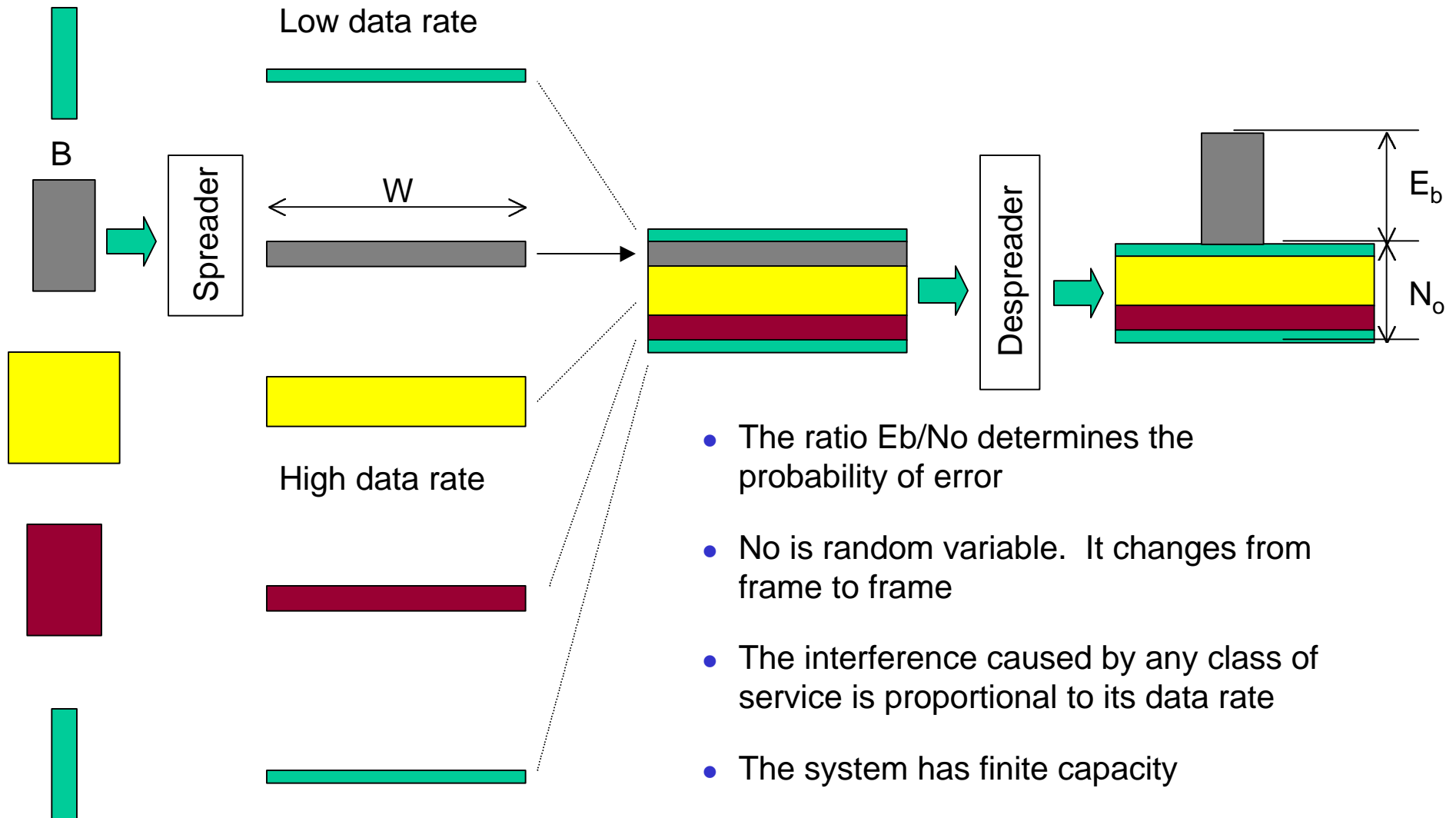

- The ratio  $E_b/N_o$  determines the probability of error
- $N_o$  is random variable. It changes from frame to frame
- The interference caused by any class of service is proportional to its data rate
- The system has finite capacity

# The $E_b/N_o$ Ratio

- u The receiver performance depends on  $E_b/N_o$
- u The effective noise,  $N_o$ , is the residual interference caused by other users at the de-spreader output
- u  $N_o$  fluctuates with time depending on who is transmitting during the frame
- u Different users can operate at different data rates with different frame activities

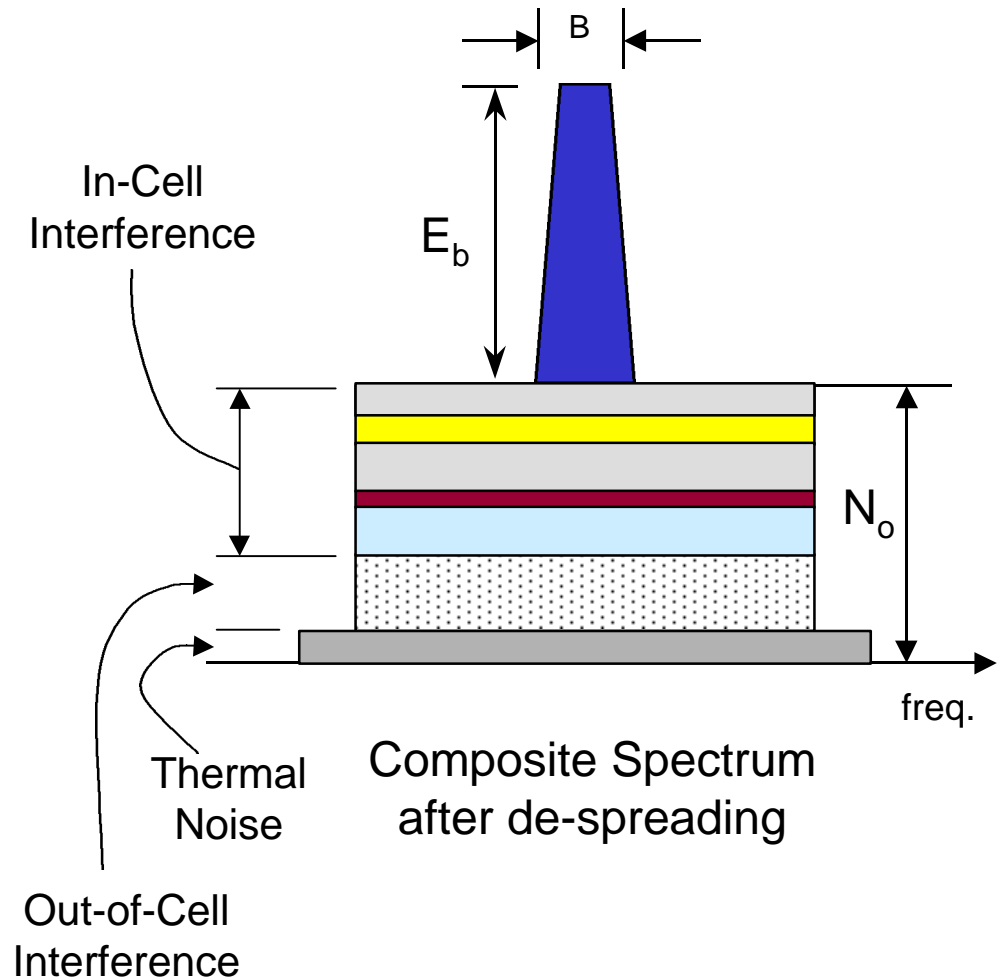

# Providing Variable QoS

- u Two aspects of QoS: (1) Delay and (2) BER
- u The delay aspect is handled by scheduling and priority schemes
- u Better BER is achieved
  - n ARQ (if the extra delay is tolerable); or
  - n Increase the  $E_b/N_o$
- u There are several ways to increase the  $E_b/N_o$  for a given user:
  - n Transmit more power
  - n Apply heavier FEC
  - n Increase the processing gain (by reducing the data rate)
  - n Increase the antenna gain (Digital Beam Forming)

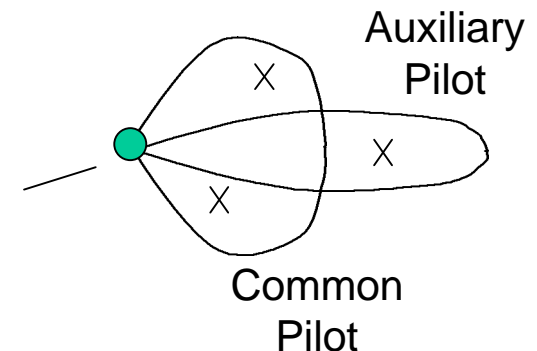
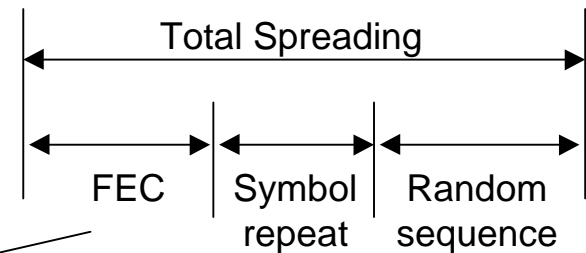

# The Competing CDMA Technologies

	Europe (UTRA)	Japan (ARIB)	NA (Cdma2000)
RF Bandwidth	1.25 / 5 / 10 /20 MHz	1.25 / 5 / 10 /20 MHz	1.25 / 5 / 10 /20 MHz
Chip Rate (Mcps)	1.024 x N (1, 4, 8, 16)	1.024 x N (1, 4, 8, 16)	1.2288 x N (1, 3, 9, 12)
Frame length	10 ms	10 ms (20 ms optional)	5 / 20 ms
Modulation	QPSK/BPSK (FDD)	QPSK/BPSK (FDD)	QPSK/BPSK
FL/RL	QPSK/QPSK (TDD)	QPSK/QPSK (TDD)	
Power Control	1600 bps	1600 bps	800 bps
Coherent Detection	Pilot Symbols/	Pilot Symbols/	Pilot Channel/
FL/RL	Pilot Symbols	Pilot Symbols	Pilot Symbols
Base to Base Synchronization	Not required	Not required	Required (GPS)

# Cdma2000 Highlights

## Example: N=3 (5 MHz)

- Two options for the FL :  
(1) Multi-Carrier; or  
(2) Direct Spreading
- The RL uses Direct spreading

## Flexibility

- Base stations can serve different populations of terminals (including IS-95)
- Overlaid systems of different bandwidths
- Flexibility in terms of growth and adapting to different markets

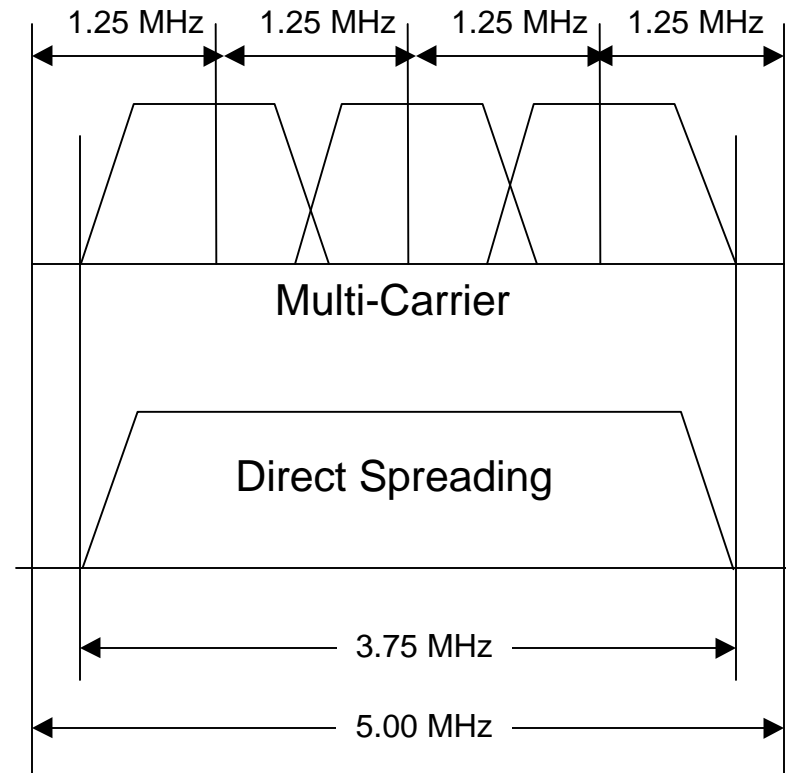

## Example of overlaid systems

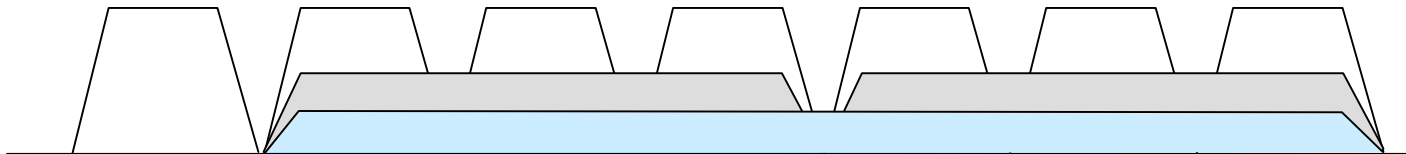

# Cdma2000 F/L Multi-Carrier Spreading

Example: N=3 (5 MHz)

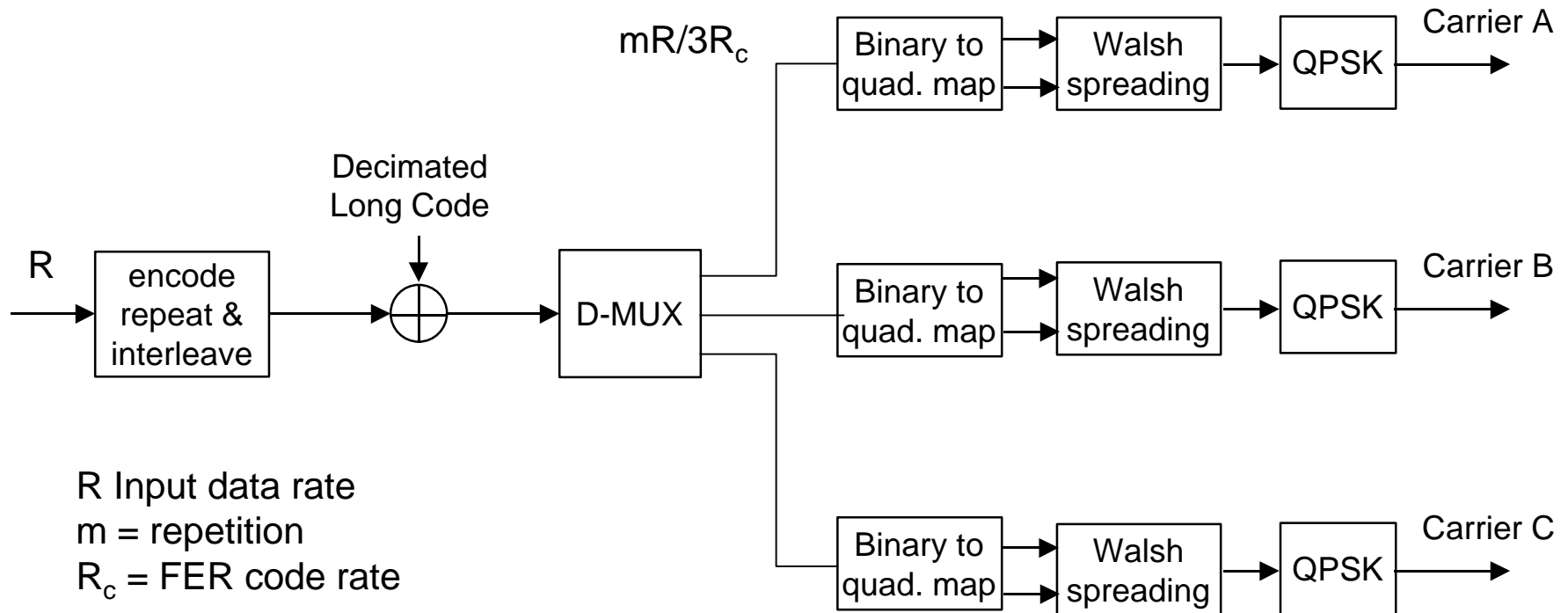

# Key Cdma2000 Design Characteristics

## (1) F/L and R/L Coherent Reception

- Pilot-based coherent reception
- Rake receiver with searcher

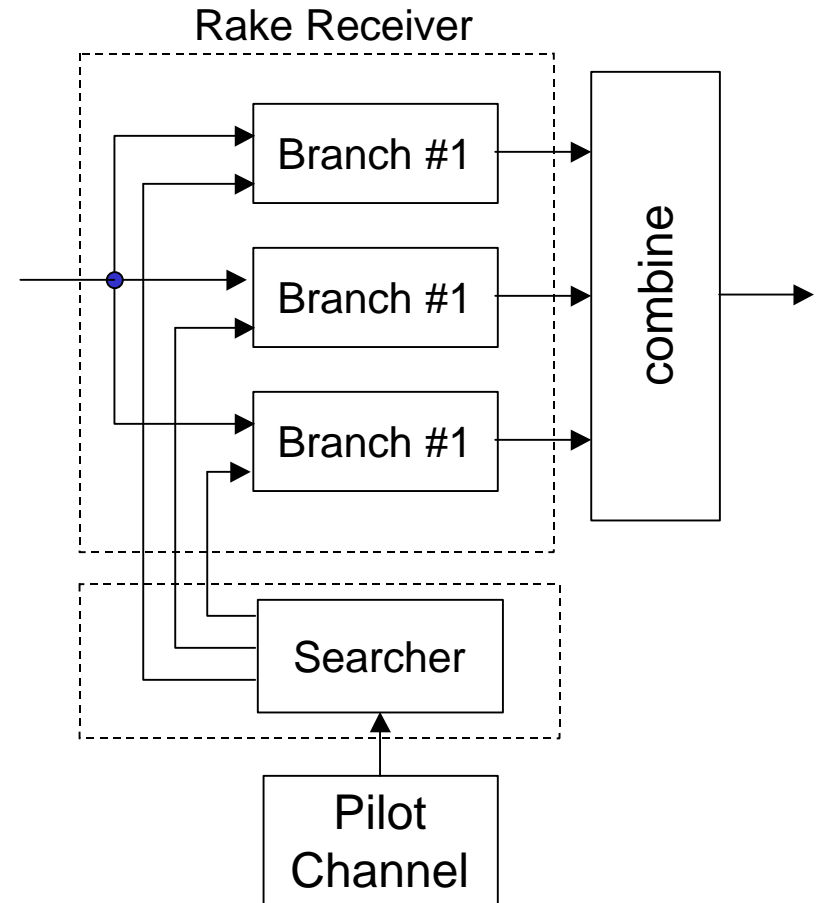
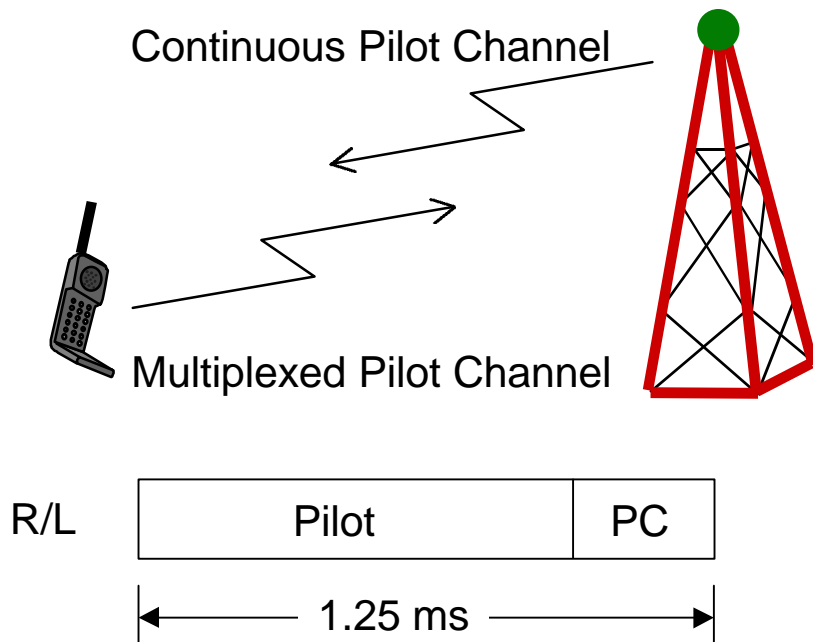

# Key Cdma2000 Design Characteristics (cont.)

---

## (2) F/L and R/L Fast Power Control

- 800 bps power control sub-channel for closed Loop power control
- Open loop power control for gross power adjustment
- Outer loop power control for inter-cell power control adjustment

## (3) Improved Soft-Hand-off Algorithm

- Provides 3 to 4 dB gain to mobiles at the edge of the cell
- Main improvement over IS-95 is the Dynamic Soft Hand-off Threshold

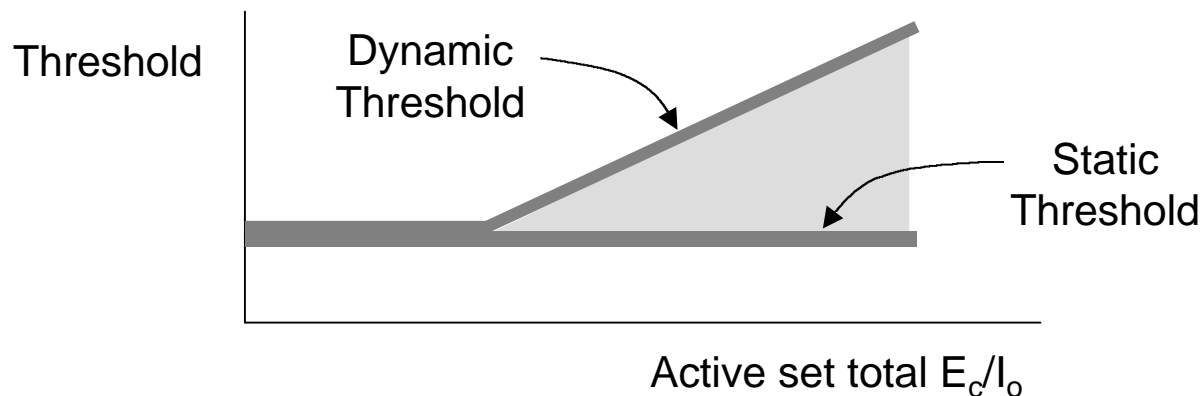

# Key Cdma2000 Design Characteristics (cont.)

## (4) Auxiliary Pilots

- Auxiliary pilots are available for implementing digital beam forming
- users that may benefit from A.P.s are those at the edge of cells or ones with demanding BER requirement
- A.P. can also be used to enhance the system capacity

## (5) Orthogonal Transmit Diversity (OTD)

- OTD is employed in the F/L to improve the system capacity
- By splitting the coded data into 2 or more streams increases the processing gain

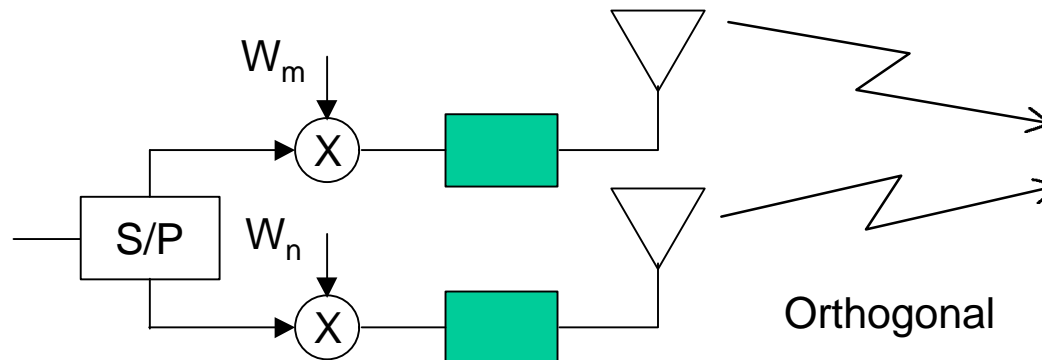

# Key Characteristics of 3G Networks

---

- So far, there is no agreement on the RTT. Most likely there will be several RTT technologies (both 3G and 2G). There will be a good market for multimode terminals (Software Radio ?!)
- WRC-99 outlined the need for Global Radio Control Channel (RCC) to help in international roaming.
- The global RCC is expected to broadcast helpful information, including:
  - IMT-2000 bands
  - Clocks and timing references
  - Identifications of public and private networks
  - Availability of services ...etc
- 3G networks will evolve from existing networks
- It is expected that the network aspects will converge more smoothly than the RTT aspects

# ITU Model for IMT-2000 Interfaces

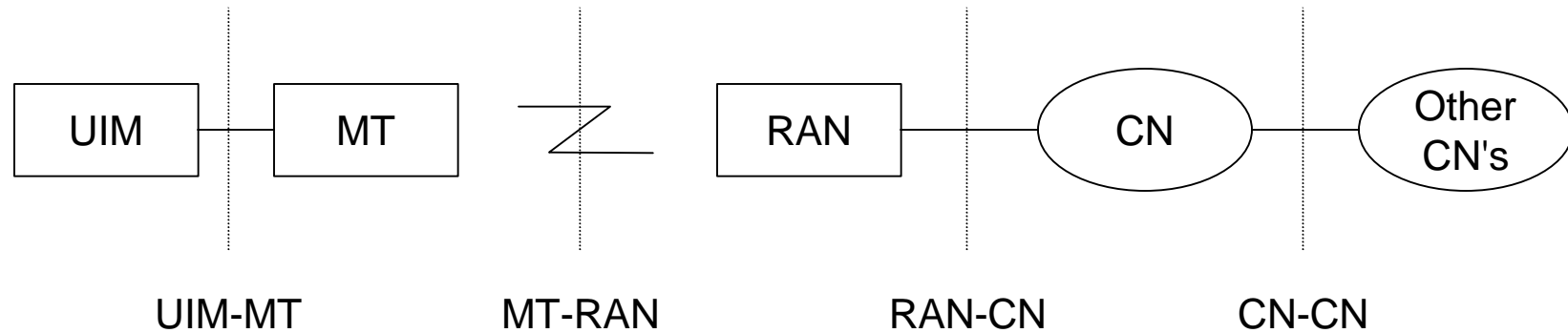

UIM User Identity Module  
MT Mobile Terminal  
RAN Radio Access Network  
CN Core Network

- The CN-CN interface is key for global roaming :
- ITU study group 11 (ITU-T-SG-11) is currently investigating a common signaling protocol for this interface.

# Interworking Scenarios

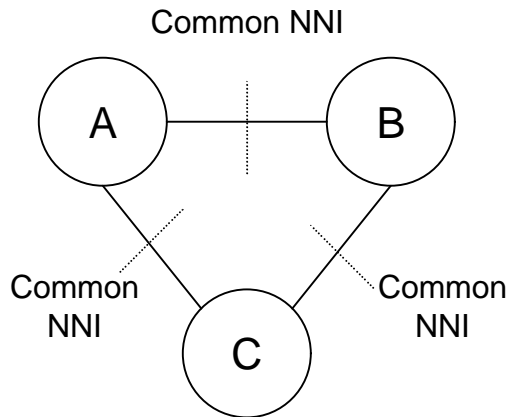

- Ultimate goal
- No Interworking facilities
- Unlikely

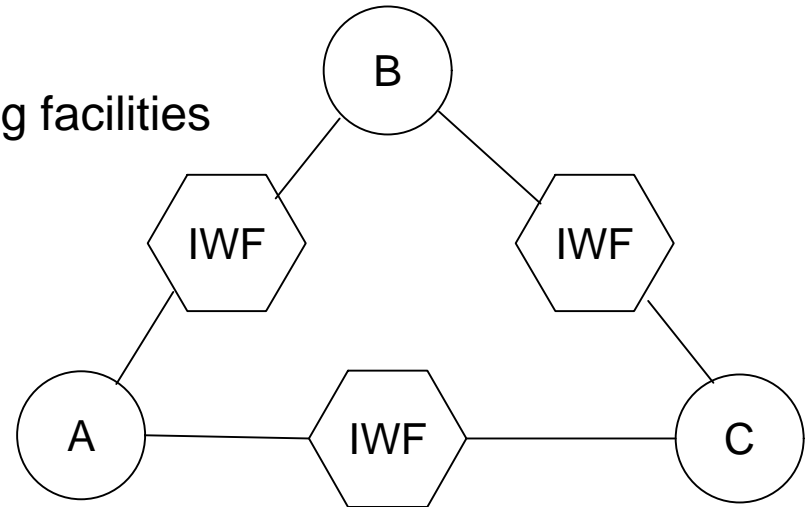

- Different network protocols
- One IWF per network
- The IWF converts into a common protocol

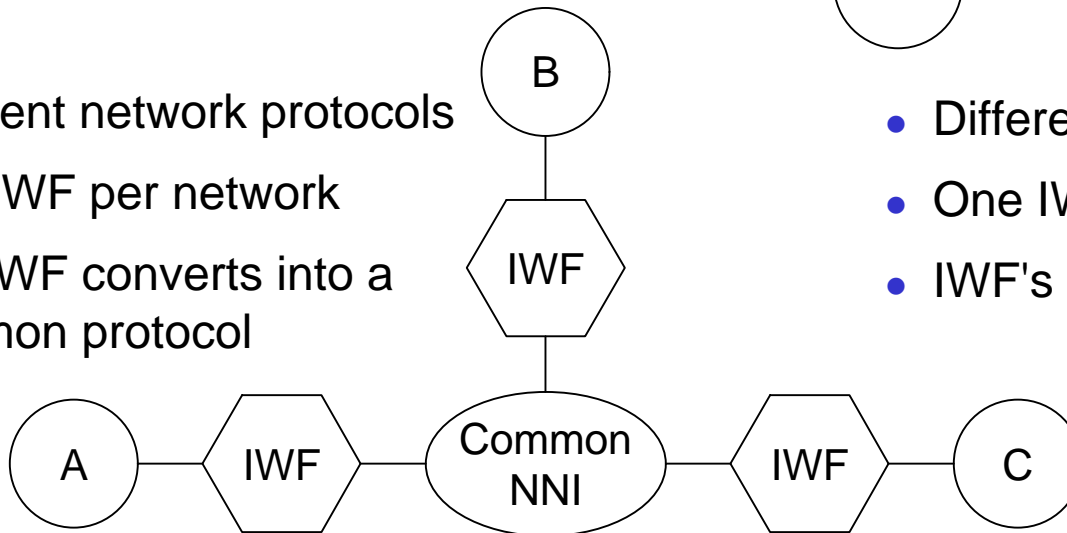

- Different network protocols
- One IWF per Interface
- IWF's are different

# Active Research Area

---

- Call admission algorithms. It involves joint optimization of:
  - Power assignment
  - Han-off (Mandatory and forced)
  - QoS Provisioning
- Optimizing the system capacity and admission procedures using auxiliary pilots
- Hybrid Space-Division-Multiple-Access (SDMA) and CDMA within the Cdma2000 frame work
- Classical ARQ-FEC trade-off in the context of power assignment to multimedia wireless terminals