

# Scheduling

Sources: 1. B. Bruegge and A. H. Dutoit, Object-Oriented Software Engineering: Using UML, Patterns, and Java (Chapter 14)

Carleton SYSC4106/TTMG5006 - Software Project Management 3-1

### Where are we?

- ▣ SPMP IEEE Std 1058
- ▣ 0. Front Matter
- ▣ 1. Introduction
- ▣ 2. Project Organization
- ▣ 3. Managerial Process
- ▣ 4. Technical Process
- ▣ 5. Work Elements, Schedule, Budget
  - ▣ 5.1 Work Breakdown Structure
  - ▣ 5.2 Dependencies between tasks
    - 5.3 Resource Requirements
    - 5.4 Budget
    - 5.5 Schedule (This lecture)
- ◆ Optional Inclusions

Carleton SYSC4106/TTMG5006 - Software Project Management 3-2

### Outline

- ◆ The last lecture dealt with Work Breakdown Structures
- ◆ Today we focus on Dependencies and Scheduling
- ◆ Estimating times for activities
- ◆ Determining critical path and slack times
- ◆ Determining project duration
- ◆ Many heuristics and examples
  - ◆ How to live with a given deadline
  - ◆ Optimizing schedules
  - ◆ Rearranging schedules

Carleton SYSC4106/TTMG5006 - Software Project Management 3-3

### Dependency Diagrams (Overview)

- ◆ Dependency diagrams consist of 3 elements
- ◆ **Event** (also called **milestone**): A significant occurrence in the life of a project.
- ◆ **Activity**: Work required to move from one event to the next.
- ◆ **Span time** (also called **duration** or **elapsed time**): The actual calendar time required to complete an activity.
  - ◆ Span time parameters: people's availability, parallelizability of the activity, availability of nonpersonnel resources, ....
- ◆ **Dependency Diagram** are drawn as a connected graph of nodes and arrows.
- ◆ 2 commonly used diagram notations to display dependency diagrams:
  - ◆ 1) **Activity-on-the-arrow** (Mealy automaton)
  - ◆ 2) **Activity-in-the-node** (Moore automaton)

Carleton SYSC4106/TTMG5006 - Software Project Management 3-4

### Why Dependency Diagrams?

- ◆ Example:
  - ◆ You are assigned a project consisting of 10 activities which take one week each to be completed.
  - ◆ How long does the project take?
- ◆ When projects have more than 15-20 activities, one cannot compute the schedule in the head any more.
- ◆ Dependency Diagrams are a formal notation to help in the construction and analysis of *complex schedules*

Carleton SYSC4106/TTMG5006 - Software Project Management 3-5

### 1) Activity-on-the-arrow Diagram Notation

Carleton SYSC4106/TTMG5006 - Software Project Management 3-6

## PERT

- PERT is an activity-on-the-arrow notation
- PERT = Program Evaluation and Review Technique
- Developed in the 50s to plan the Polaris weapon system in the USA.
- PERT allows to assign optimistic, pessimistic and most likely estimates for the span times of each activity.
- You can then compute the probability to determine the likelihood that overall project duration will fall within specified limits.

## 2) Activity-in-the-node Diagram Notation

A Node is either an event or an activity.  
Distinction: Events have span time 0

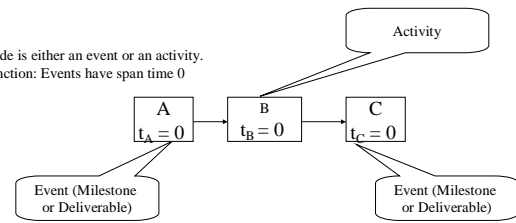

Milestone boxes are often highlighted by double-lines

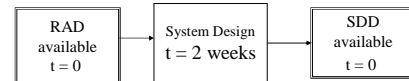

## Example of an Activity-in-the-Node Diagram

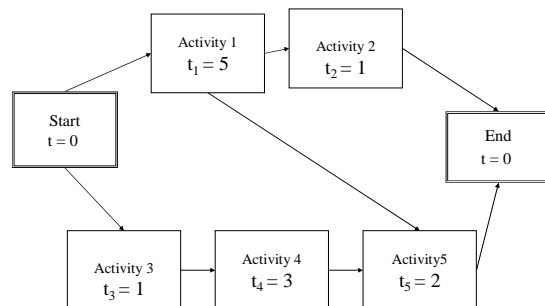

## What do we do with these diagrams?

- Compute the project duration
- Determine activities that are critical to ensure a timely delivery
- Analyse the diagrams
  - to find ways to shorten the project duration
  - To find ways to do activities in parallel
- 2 techniques are used
  - Forward pass (determine critical paths)
  - Backward pass (determine slack time)

## Definitions: Critical Path and Slack Time

- **Critical path:**
  - A sequence of activities that take the longest time to complete
  - The length of the critical path(s) defines how long your project will take to complete.
- **Noncritical path:**
  - A sequence of activities that you can delay and still finish the project in the shortest time possible.
- **Slack time:**
  - The maximum amount of time that you can delay an activity and still finish your project in the shortest time possible.

## Example of a critical path

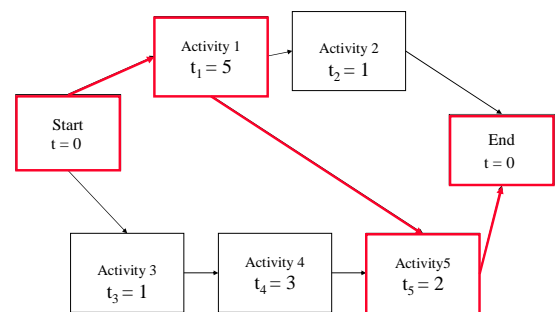

Critical path in bold face

### Definitions: Start and Finish Dates

- Earliest start date:
  - The earliest date you can start an activity
- Earliest finish date:
  - The earliest date you can finish an activity
- Latest start date:
  - The latest date you can start an activity and still finish the project in the shortest time.
- Latest finish date:
  - The latest date you can finish an activity and still finish the project in the shortest time.

### 2 Ways to Analyze Dependency Diagrams

- **Forward pass:** Goal is the determination of **critical paths**
  - Compute earliest start and finish dates for each activity
  - Start at the beginning of the project and determine how fast you can complete the activities along each path until you reach the final project milestone.
- **Backward pass:** Goal the determination of **slack times**
  - Compute latest start and finish dates activity
  - Start at the end of your project, figure out for each activity how late it can be started so that you still finish the project at the earliest possible date.
- To compute start and finish times, we apply 2 rules
  - **Rule 1:** After a node is finished, we can proceed to the next node(s) that is reachable via a transition from the current node.
  - **Rule 2:** To start a node all nodes must be completed from which transitions to that node are possible.

### Forward Path Example

Project Duration = 7

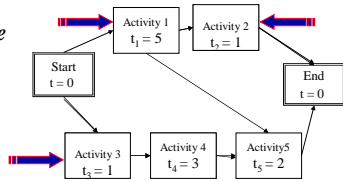

Activity	Earliest Start(ES)	Earliest Finish(EF)
A1	Start of week 1	End of week 5
A2	Start of week 6	End of week 6
A3	Start of week 1	End of week 1
A4	Start of week 2	End of week 4
A5	Start of week 6	End of week 7

### Backward Path Example

Project Duration = 7

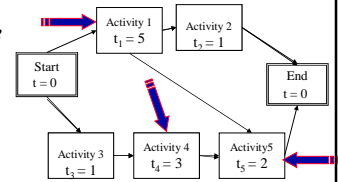

Activity	Latest Start(LS)	Latest Finish(LF)
A1	Start of week 1	End of week 5
A2	Start of week 7	End of week 7
A3	Start of week 2	End of week 2
A4	Start of week 3	End of week 5
A5	Start of week 6	End of week 7

### Computation of slack times

- Slack time ST of an activity A:
  - $ST_A = LS_A - ES_A$
  - Subtract the earliest start date from the latest start date for each activity

Example:  $ST_{A4} = 3 - 2 = 1$

Slack times on the same path influence each other.

Example: When Activity 3 is delayed by one week, activity 4 slack time becomes zero weeks.

Activity	Slack time
A1	0
A2	1
A3	1
A4	1
A5	0

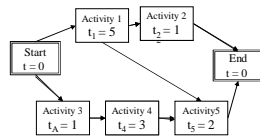

### Path types in dependency graphs

- **Critical path:** Any path in a dependency diagram, in which all activities have zero slack time.
- **Noncritical path:** Any path with at least one activity that has a nonzero slack time.
- **Overcritical path:** A path with at least one activity that has a negative slack time.
  - Overcritical paths should be considered as serious warnings: Your plan contains unreal time estimates
- Any dependency diagram with no fixed intermediate milestones has at least one critical path.
- A project schedule with fixed intermediate milestones might have no critical path
  - Example: The analysis review must be done 1 month after project start, the estimated time for all activities before the review is 3 weeks.

### Frequently used formats for dependency graphs

- ◆ Milestone View (“Key-Events report”):
  - A table that lists milestones and the dates on which you plan to reach them.
- ◆ Activities View:
  - A table that lists the activities and the dates on which you plan to start and end them
- ◆ Gantt chart View:
  - A graphical illustrating on a timeline when each activity will start, be performed and end.
- ◆ Combined Gantt Chart and Milestone View:
  - The Gantt Chart contains activities as well as milestones.

### Key-Events Report

Date	Milestone
August 26	Project Kickoff (with Client)
October 16	Analysis Review
October 26	System Design Review
November 7	Internal Object Design Review
November 20	Project Review (with Client)
Nov 26	Internal Project Review
Dec 11	Acceptance Test (with Client)

Good for introduction of SPMP and high executive briefings

### Activities View

Date	Project Phases
Jul 17-Aug 23	Preplanning Phase
Aug 26 - Sep 24	Project Planning
Sep 11-Oct 8	Requirements Analysis
Oct 9 - Oct 26	System Design
Oct 28-Nov 7	Object Design
Nov 8 - Nov 20	Implementation & Unit Testing
Nov 22 - Dec 4	System Integration Testing
Dec 4 - Dec 10	System Testing
Dec 11- Dec 18	Post-Mortem Phase

Good for SPMP Section 5.5 and during developer meetings

### Gantt Chart

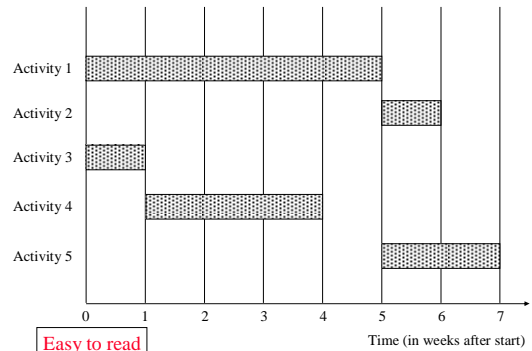

### Gantt Chart with milestones

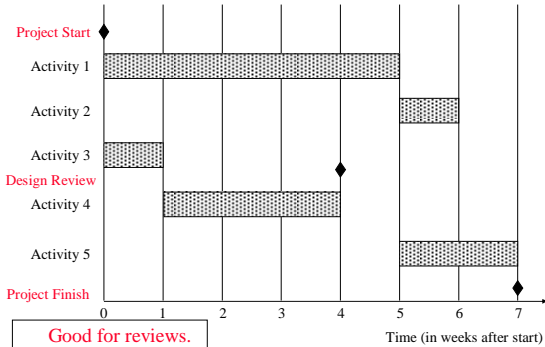

### Two Types of Gantt Charts

- ◆ Person-Centered View
  - To determine people's load
- ◆ Activity-Centered View
  - To identify teams working together on the same tasks

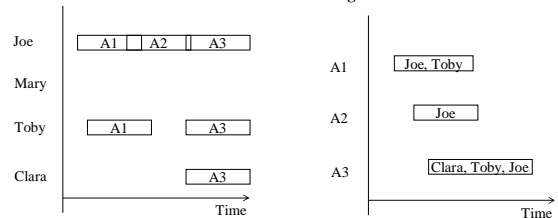

Choose one view, stay with it. Usually base the view on the WBS structure  
 Managing Experienced Teams: Person-centered view  
 Managing Beginners: Activity oriented view

### Tools support for Establishing Schedules

- ◆ Tool support for
  - Graphical user interface for entering activity data
  - Automatic computation of critical paths
  - Multiple views (PERT, Gantt, table views) and switching between these views
- ◆ Many products available. Examples
  - Fast Track (Demo)  
([http://www.aecsoft.com/downloads/demo/downloads\\_listindex.asp?bhcp=1](http://www.aecsoft.com/downloads/demo/downloads_listindex.asp?bhcp=1))
    - Main view: Gantt Charts
  - Microsoft Project  
(<http://www.microsoft.com/office/project/default.asp>)
    - PERT Charts, Gantt Charts, combined Milestone/Gantt Charts
- ◆ Tool use and training beyond the scope of this class

### How to develop an Initial Project Schedule

- ◆ Identify all your activities (reuse a template if possible)
- ◆ Identify intermediate and final dates that must be met
  - Assign milestones to these dates
- ◆ Identify all activities and milestones outside your project that may affect your project's schedule
- ◆ Identify "depends on" relationships between all these identified activities
- ◆ Draw a dependency diagram for all identified activities and relationships
- ◆ Analyze the diagram to determine critical paths and slack times of noncritical paths.
- ◆ Example: Establish a schedule for system integration testing

### Developing a Schedule for Integration Testing

Five Steps:

1. Start with System Decomposition
2. Determine your Integration Testing Strategy
3. Determine the Dependency Diagram (UML Activity Diagram)
4. Add Time Estimates
5. Visualize the activities on a time scale: Gantt Chart

See Bruegge&Dutoit 2003, Chapter 9 Testing

### 1. Start with System Decomposition

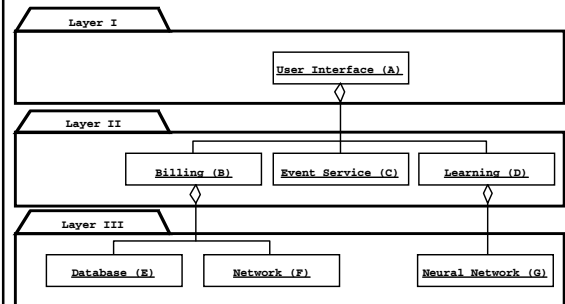

### 2. Determine Your Integration Testing Strategy

- ◆ Types of integration testing strategies
- ◆ We choose sandwich testing. Why?
  - It allows many parallel testing activities, possibly shortening testing time
- ◆ Sandwich testing requires 3 layers
  - Reformulate the system decomposition into 3 layers if necessary
- ◆ Identification of the 3 layers and their components in our example
  - Top layer: A
  - Target layer: B, C, D
  - Bottom layer: E, F, G

### Sandwich Testing

- ◆ Sandwich testing combines parallel top-down and bottom-up integration testing
  - Top-down testing tests the top layer incrementally with the components of the target layer
  - Bottom-up testing tests the bottom layer incrementally with the components of the target layer
- ◆ Modified sandwich testing is more thorough
  - Individual layer tests
    - Top layer test with stubs for target layer
    - Target layer test with drivers and stubs replacing top and bottom layers
    - Bottom layer test with a driver for the target layer
  - Combined layer tests
    - Top layer access the target layer
    - Target layer accesses bottom layer

### 3. Determine the Dependency Diagram (Sandwich Testing , UML Activity Diagram)

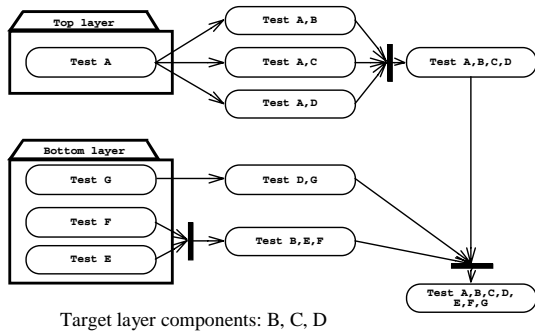

### Dependency Diagram for a Modified Sandwich Testing Strategy

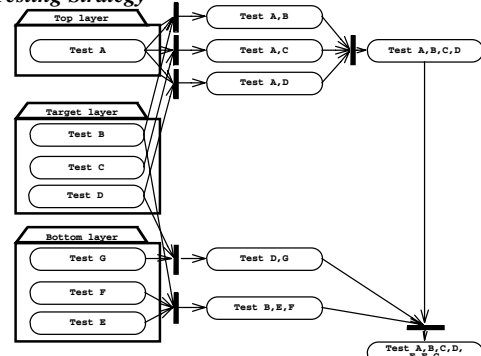

### 4. Add Time Estimates (PERT Chart)

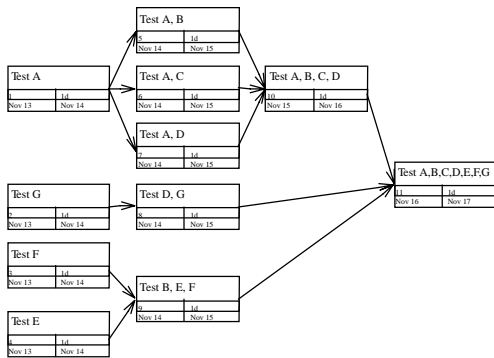

### 5. Visualize your Schedule (Gantt Chart View)

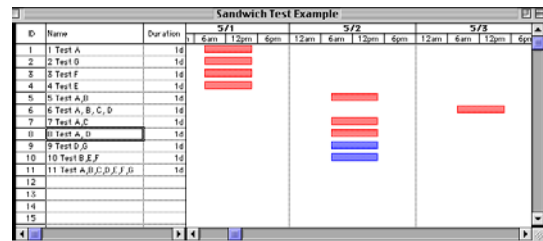

### How to reduce the planned project time

- ◆ Recheck the original span time estimates
  - Ask other experts to check the estimates
  - Has the development environment changed? (batch vs interactive systems, desktop vs laptop development)
- ◆ Hire more experienced personnel to perform the activities
  - Trade-off: Experts work fast, but cost more
- ◆ Consider different strategies to perform the activities
  - Consider to Buy a work product instead of building it (Trade-off: Buy-vs-build)
  - Consider extern subcontractor instead of performing the work work internally
- ◆ Try to find parallelizable activities on the critical path
  - Continue coding while waiting for the results of a review
  - Risky activity, portions of the work may have to be redone.
- ◆ Develop an entirely new strategy to solve the problem

### Typical Mistakes when Developing Schedules

- ◆ The “Backing in” Mistake
- ◆ Using Fudge Factors

### The “Backing in” Mistake

- ◆ Definition “Backing In”:
  - You start at the last milestone of the project and work your way back toward the starting milestone, while estimating durations that will add up to the amount of the available time
- ◆ Problems with Backing in:
  - You probably miss activities because your focus is on meeting the time constraints rather than identifying the required work
  - Your span time estimates are based on what you allow activities to take, not what they actually require
  - The order in which you propose activities may not be the most effective one.
- ◆ Instead, start with computing all the required times and then try to shorten the project duration

### Using Fudge Factors

- ◆ Parkinson formulated this law for project completion:
  - Work tends to expand to fill the time allotted for it.
- ◆ Fudge factor:
  - A fudge factor is the extra amount of time you add to your best estimate of span time “just to be safe”.
  - Example: Many software companies double their span time estimates.
- ◆ Don't use fudge factors because of Parkinson's law.
  - If an activity takes 2 weeks, but you add a 50% fudge factor, chances are almost zero that it will be done in less than 3 weeks.

### Heuristics for dealing with time

1. First **Set** the Project Start Time =>
    - Determines the planned project time
    - Determine the critical path(s)
  2. Then try to **reduce** the planned project time
    - If you want to get your project done in less time, you need to consider ways to shorten the aggregate time it takes to complete the critical path.
- ◆ Avoid fudge factors

### Identifying When a Project Goes Off-Track

- ◆ Determine what went wrong: Why is your project got off track?
  - Behind schedule
  - Overspending of resource budgets
  - Not producing the desired deliverables
- ◆ Identify the Reason(s):
  - You are new on the job, this is your first project, and you made mistakes
  - Key people left the teams or new ones are joining it
  - Key people lost interest or new ones entered the picture
  - The requirements have changed
  - New technology has emerged
  - The business objectives have changed
  - Organizational priorities have shifted (for example after a merger)

### Heuristics to get a project back on track

- ◆ Reaffirm your plan
  - Reaffirm your key people
  - Reaffirm your project objectives
  - Reaffirm the activities remaining to be done
  - Reaffirm roles and responsibilities
- ◆ Refocus team direction and commitment
  - Revise estimates, develop a viable schedule
  - Modify your personnel assignments
  - Hold a midproject kickoff session
  - Closely monitor and control performance for the remainder of the project
- ◆ Get practical experience

### What makes a Software Project successful?

- ◆ User involvement 20
  - ◆ Support from upper management 15
  - ◆ Clear Business Objectives 15
  - ◆ Experienced Project Manager 15
  - ◆ Shorter project phases („Small milestones“) 10
  - ◆ Firm core requirements („basic requirements“) 5
  - ◆ Competent Staff 5
  - ◆ Proper Planning 5
  - ◆ Ownership 5
  - ◆ Other 5
- 100 %

From Standish Group [http://www.standishgroup.com/sample\\_research/chaos1998.pdf](http://www.standishgroup.com/sample_research/chaos1998.pdf)

### Become a better *software* project manager

- ◆ End User and Management involvement 35%
  - ◆ Learn how to involve the customer and end users
  - ◆ Learn how to get support from your upper management
- ◆ Practice project management 30 %
  - ◆ Do as many projects as possible
  - ◆ Learn from your project failures
- ◆ Focus on business objectives and requirements 20%
  - ◆ Distinguish between core, optional and fancy requirements

### How to become a better project manager

- ◆ Don't assume anything
  - ◆ Take the time to find out the facts.
  - ◆ Use assumptions only as a last resort.
  - ◆ With every assumption comes a risk that you are wrong.
- ◆ Communicate clearly with your people.
  - ◆ Being vague does not get you more leeway, it just increases the chances for misunderstanding.
- ◆ Acknowledge good performance
  - ◆ Tell the person, the person's boss, team members, peers.
- ◆ View your people as allies not as adversaries
  - ◆ Focus on common goals, not on individual agendas.
  - ◆ Make people comfortable by encouraging brainstorming and creative thinking
- ◆ Be a manager and a leader
  - ◆ Deal with people as well as to deliverables, processes and systems.
  - ◆ Create a sense of vision and excitement.

### Additional Readings

- ◆ [IEEE Std 1058] Standard for Software Project Management Plans
- ◆ Standish Group: Chaos, Sample Research Paper, 1998  
[http://www.standishgroup.com/sample\\_research/chaos1998.pdf](http://www.standishgroup.com/sample_research/chaos1998.pdf)
- ◆ [Royse 1998], Software Project Management, Addison-Wesley, ISBN0-201-30958-0

### Summary

- ◆ Software Project Management Plan, Section 5:
  - 5.1 Work Breakdown Structure
  - 5.2 Dependencies between tasks
  - 5.3 Resource Requirements (=> Lecture on project organization)
  - 5.4 Budget (=> Lecture on project estimation)
  - 5.5 Schedule
- ◆ **Work Breakdown Structure (WBS):** Set of activities to do ("use cases")
- ◆ **Dependency Graph:** Identification of dependency relationships between activities identified in the WBS
- ◆ **Schedule:** Dependency graph decorated with time estimates for each activity
- ◆ **PERT:** One of the first techniques proposed to analyse complex dependency graphs and schedules
- ◆ **Gantt Chart:** Simple notation used to visualize a schedule

### Summary: Another view:-)

- ◆ Developing a project plan is an art. Practice it!
- ◆ Use project templates for yourself or your organization, build these templates iteratively
- ◆ There are several different ways to do a WBS (activity-oriented, entity-oriented, ...)
- ◆ The detailed planning horizon should not go beyond a 3 month time frame
- ◆ Innovative projects with changing requirements or technology enablers should include an initial planning phase that results in a project agreement.
- ◆ A dependency graph is the WBS plus dependencies.
- ◆ A schedule is a dependency graph plus time estimates
- ◆ Budget should not be specified before the work is clear:
  - ◆ If the preplanning phase needs a budget, ask for a separate budget