

Background: You get a job working for a company that wants to design “high tech” sports equipment. This equipment will monitor the heart rate and other physiological parameters of the customers while they’re working out. These data will then be wirelessly transmitted via bluetooth to a software module that can be installed onto the customers laptop, PDA or smartphone. The key business drivers for these products is the ability of customers to monitor their exercise performance over time, so the company plans to develop web applications which allow participation in online fitness forums.

Your job will be to design a monitoring system for a set of weights, as shown in the sketch. A set of stainless steel electrodes is placed into a bar for weightlifting, which measure the voltage difference between the hands. From the measured signals we hope to get a measure of both the *heart* and *muscle* activity. Additionally, you are asked to do a set of calibration test on a set of volunteers in order to determine the accuracy of the equipment.

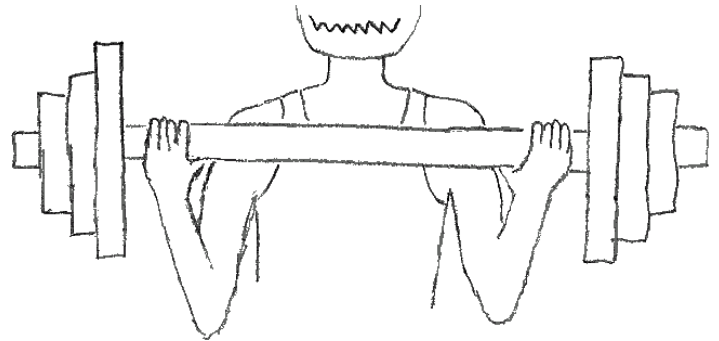

Instructions: Answer question #1. Answer any 7 of the remaining 8 questions.

1. (1 point) Your exam is exam number 2. Write “I’ve got exam #2.”
2. (5 points) The heart electrical activity may be characterized with 3D with a vector potential. **a) Sketch a diagram of a heart, the three Einthoven leads, and show how this corresponds to a vector potential. b) Which of the Einthoven leads is measured by this exercise system.**
3. (5 points) One concern with this electrode system is the sweat which will accumulate on the hands. Using a sketch of an electrical equivalent model of the skin, **indicate how sweat will change the electrode properties.**
4. (5 points) **Sketch a block diagram of a “driven right leg” circuit.** If you use an amplifier, indicate what its gain should be at DC and at high frequency.

5. (5 points) One key source of interference is from electromagnetic interference at powerline frequencies (50 Hz in Europe). This will typically appear as a common mode signal. If difference signal of interest is 1.5 mV, and the power line interference signal is 100 mV, **what CMRR is required so that the difference signal is 10× larger than the interference?** Assume V_{cm} is the power line interference signal.

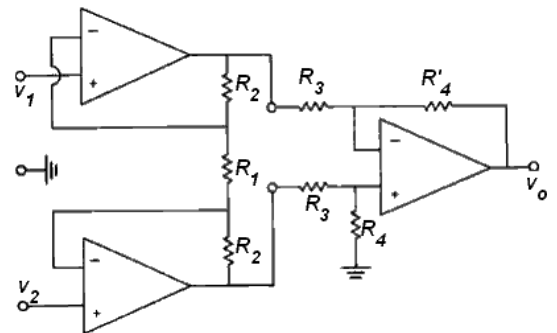

6. (5 points) Consider an instrumentation amplifier as shown at right, where $V_o = (1 + 2\frac{R_2}{R_1})\frac{R_4}{R_3}(V_1 - V_2)$. **Calculate A_d when $R_1 = 1.0\text{ k}\Omega$, $R_2 = R_3 = 20\text{ k}\Omega$, and $R_4 = R'_4 = 10.0\text{ k}\Omega$.**
7. (5 points) **Calculate A_{cm} when $R_1 = 1.0\text{ k}\Omega$, and $R_2 = R_3 = 20\text{ k}\Omega$, $R_4 = 10.0\text{ k}\Omega$, and $R'_4 = 10.1\text{ k}\Omega$.**
8. (5 points) In order to separate the heart and muscle signals, we consider using a set of filters. We use a low pass filter with a cut-off frequency at 10 Hz to estimate the ECG, and a high pass filter with a cut-off at 100 Hz to estimate the EMG. **Given the frequency content of the ECG and EMG signals, describe (≤ 50 words) the output of these circuits.** Use a sketch if appropriate.
9. (5 points) Your company wants to consider an advanced version of this product, in which a measure blood pressure is measured from the *pulse transit time* (PTT), defined as the time from QRS peak to finger arterial pressure peak. Assume you have a measure of the blood volume in a finger (using *photoplethysmography*, which we will discuss later in the course). Assume the shape of the blood volume curve is roughly proportional to the arterial pressure in the finger. **Sketch the relationship between the arterial pressure and the ECG waveform**, showing the timing of the pulses and when the aortic valve opens and closes. Assuming a value of $PTT=0.34\text{ s}$ is measured, **add a graph of finger arterial pressure to your sketch.**