

CARLETON UNIVERSITY
Department of Systems and Computer Engineering

SYSC5608 – Wireless Communications Systems Engineering – Fall 2010

Term Exam

11 November 2010 – Prof. H. Yanikomeroglu

Closed-book. One-page aid-sheet is permitted. 20 bonus points.

Instructions: Write answers in the spaces provided on the question sheet. If necessary, use both sides of a page. Write legibly, and state any assumptions that you make. A blank page is provided after the last question.

Name:

Student Number:

E-mail:

| Question | Mark | out of |
|--------------|------|------------|
| 1 | | 45 |
| 2 | | 30 |
| 3 | | 45 |
| Total | | 120 |

Question 1 (45 pts) Transmission Through A Bandlimited Channel

A baseband 16-ary communication system with zero-mean AWGN is shown in the below figure where T denotes the symbol duration. The channel is an ideal LPF with bandwidth W Hz. The transmitter and receiver filters, $h_T(t)$ and $h_R(t)$, constitute a matched filter pair; i.e., $|H_T(f)| = |H_R(f)|$. In the below figure the product $|H_T(f)||H_R(f)|$ is shown as well.

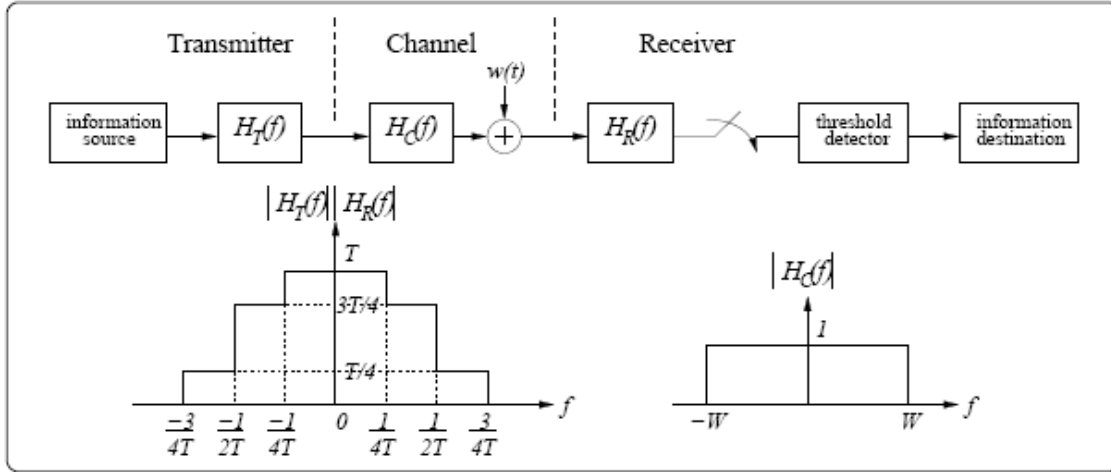

(a) (5 pts) Find the maximum symbol rate R_s , in term of W , for which the channel will not cut the transmitted signal.

(b) (15 pts) At this maximum symbol rate, does the overall system introduce ISI? Justify your answer clearly with the help of a sketch.

(c) (10 pts) If $W = 3$ MHz, what is the maximum bit rate, R_b , of this system?

(d) (10 pts) If the bit rate has to be at least 23 Mbps, what constellation size has to be used instead of 16-ary? In other words, what would be M in the corresponding M -ary case?

(e) (5 pts) Consider another LPF channel with the same W Hz bandwidth, but with non-ideal passband characteristics (i.e., channel causes spectral shaping). Given that $h_T(t)$ and $h_R(t)$ are the same as above, what operation has to be done at the receiver to remove the ill-effects caused by this channel. Discuss qualitatively.

[Space for Question 1]

[Space for Question 1]

Question 2 – Short Questions [30 points]

a) [10 pts] Suppose that you are involved in the design of a next-generation cellular network which targets to deliver an aggregate rate of 1 Gbps per base-station in the downlink. Choose some appropriate

- bandwidth,
- spectral efficiency, and
- number of antenna (for MIMO gain)

values for this network.

b) [5 pts] What is the data rate for voice commonly used in current wireless cellular networks?

c) **[10 pts]** In a wireless cellular network with a fix number of BSs, if the cluster size is increased from 3 to 4, what percentage does the total network capacity increase or decrease?

d) **[5 pts]** The adaptive modulation and coding (AMC) level in a wireless system is specified as “64-QAM with rate-7/8”; find the spectral efficiency if the square-root raised cosine (SRRC) pulses are used with a roll-off factor of $\alpha=0.18$.

Question 3 [45 marks] – Power Calculations in Wireless Communications

Consider a straight line with equidistant points A, B, C, D, and E on it such that $|AB| = |BC| = |CD| = |DE|$.

Assume that there is a Base Station located at point A with transmit power P_A Watts. The power levels received at wireless terminals located at points B, C, D, and E are denoted by P_B , P_C , P_D , and P_E , respectively.

The following deterministic propagation model relates the received power P_r to the transmit power P_t in the given environment:

$$P_r = P_t G_t G_r C_1 \left(\frac{\lambda}{4\pi d_0} \right)^2 \left(\frac{d_0}{d} \right)^n C_2.$$

In the above,

- d : distance between the transmitter and receiver
- $d_0 = 25$ m: reference distance
- C_1 : correction factor for the terrain type (same for all points)
- C_2 : correction factor for the transmit and receive antenna heights (same for all points).

(a) [35 pts] Find the following in terms of the system parameters:

$$\Delta P_{BC} = P_B \text{ [dBm]} - P_C \text{ [dBm]}$$

$$\Delta P_{BD} = P_B \text{ [dBm]} - P_D \text{ [dBm]}$$

$$\Delta P_{DE} = P_D \text{ [dBm]} - P_E \text{ [dBm]}$$

(b) [10 pts] Sketch ΔP_{DE} [dB] (vertical axis) as a function of $|DE|$ [m] (horizontal axis), for $n=3.8$. Use the logarithmic scale in the horizontal axis; for instance, you may evaluate ΔP_{DE} for $|DE| = 100$ m, 1 km, 10 km.

[Space for Question 3]

[Space for Question 3]